

Total: 2 pages

Date: 1 March 2024

TPB Ref.: A/HSK/509

By Email

Town Planning Board
15/F, North Point Government Offices
333, Java Road
North Point
Hong Kong
(Attn: The Secretary)

Dear Sir,

Proposed Temporary Warehouse for Storage of Food Provision for a Period of 3 Years at Lots 673 (Part), 674 (Part), 675 S.A, 675 S.B, 676 (Part) in D.D.125 and Adjoining Government Land, Ha Tsuen, Yuen Long, N.T.

We are glad to submit the updated landscape plan for your further processing of the captioned planning application.

Should you have any enquiries, please feel free to contact our Mr. Patrick Tsui at 5114 9258 at your convenience.

Yours faithfully,

The image shows a handwritten signature in black ink, which appears to be 'Patrick Tsui'. To the right of the signature is a purple circular stamp. The stamp contains the text 'URBAN PLANNING & DEVELOPMENT CORPORATION' around the perimeter, and in the center, the Chinese characters '都市規劃及發展顧問有限公司' (Urban Planning & Development Corporation Limited).

Patrick Tsui

c.c. Tuen Mun and Yuen Long West District Planning Office (Attn: Ms. Moon KOK) – By Email

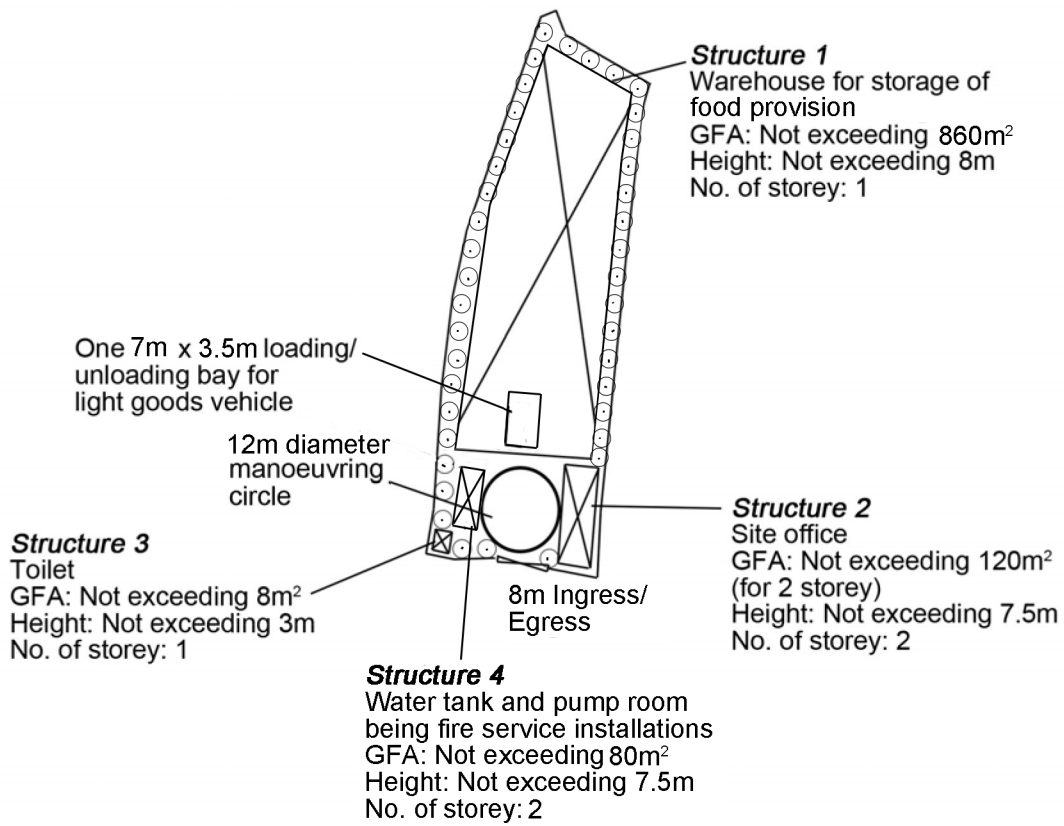

Tree	Approximate Height	Spacing	Quantity
① Existing <i>Ficus microcarpa</i> to be preserved	2.75m	3m to 4m	40

Project 項目名稱: Temporary Warehouse for Storage of Food Provision for a Period of 3 Years at Lots 673 (Part), 674 (Part), 675 S.A, 675 S.B, 676 (Part) in D.D.125 and Adjoining Government Land, Ha Tsuen, Yuen Long, N.T.	Drawing Title 圖目: Proposed Landscape Plan	Remarks 備註: Tree Preservation Measures: (i) No open storage of materials/objects will be carried out within the 1m diameter of all the trees within the site boundary; (ii) Irrigate the trees at regular interval; (iii) Replace dead tree, if any; & (iv) Removal of weeds and climbers adjacent to the existing trees.
	Drawing No. 圖號: Figure 4	