

HONG KONG

VIPASSANA MEDITATION CENTRE LIMITED

PROJECT PROFILE

REUSE OF TREATED SEWAGE EFFLUENT FROM
A TREATMENT PLANT AT
HONG KONG VIPASSANA MEDITATION CENTRE,
LANTAU ISLAND

Table of Content

1	PROJECT INFORMATION	4
1.1	Project Title.....	4
1.2	Purpose and Nature of Project	4
1.3	Name of Project Proponent.....	5
1.4	Location and Scale of Project	5
1.5	Number and Types of Designated Project Covered by this Project Profile	6
1.6	Name and Telephone Number of Contact Person.....	6
2	OUTLINE OF PLANNING AND IMPLEMENTATION PROGRAMME	6
2.1	Project Planning and Implementation.....	6
2.2	Program for TSE Reuse System Installation	6
3	MAJOR ELEMENTS OF THE SURROUNDING ENVIRONMENT.....	7
3.1	Existing and Planned Sensitive Receivers	7
3.1.1	Air Quality and Noise	7
3.1.2	Water Quality	8
3.1.3	Cultural Heritage.....	8
3.1.4	Health and Hygiene.....	8
4	POSSIBLE IMPACTS ON THE ENVIRONMENT	8
4.1	Possible Environmental Impacts during Construction Stage.....	8
4.1.1	Air Quality	8
4.1.2	Noise	8
4.1.3	Water Quality	8
4.1.4	Waste.....	9
4.1.5	Ecology	9
4.1.6	Landscape and Visual	9
4.1.7	Health and Hygiene.....	9
4.1.8	Cultural Heritage.....	9
4.2	Possible Environmental Impacts during Operation Stage	10
4.2.1	Natural Resources	10
4.2.2	Air Quality	10
4.2.3	Noise	10
4.2.4	Water Quality	11
4.2.5	Waste.....	12
4.2.6	Ecology	12
4.2.7	Health and Hygiene.....	12
4.2.8	Hazard to Life	12
4.2.9	Landscape and Visual	13

4.2.10	Cultural Heritage.....	13
5	ENVIRONMENTAL PROTECTION MEASURES TO BE INCORPORATED .	13
5.1	Environmental Protection Measures during Construction Stage.....	13
5.1.1	Air Quality	13
5.1.2	Noise	13
5.1.3	Water Quality	13
5.1.4	Waste.....	13
5.2	Environmental Protection Measures during Operation Stage.....	14
5.2.1	Air Quality	14
5.2.2	Noise	14
5.2.3	Water Quality	14
5.2.4	Waste.....	15
5.2.5	Health and Hygiene.....	15
5.2.6	Hazard to Life	15
5.3	Comments on Environmental Effects	15
6	USE OF PREVIOUSLY APPROVED REPORTS.....	15
7	SUMMARY OF POTENTIAL ENVIRONMENTAL IMPACTS AND MIGITATION MEASURES	16

1 PROJECT INFORMATION

1.1 Project Title

Reuse of treated sewage effluent from a treatment plant at Hong Kong Vipassana Meditation Centre, Lantau Island.

1.2 Purpose and Nature of Project

1.2.1 Hong Kong Vipassana Meditation Centre Limited (hereinafter called “HKVMC”) is the Hong Kong branch of the Vipassana Meditation Centres International (www.dhamma.org). It teaches a universal (regardless of religion or belief) meditation technique that can purify the mind and help free stress and tension so that people can live peacefully, happily and productively at every moment. The residential courses (1-day, 3-day, 10-day, 20-day, 30-days, etc.) are offered free-of-charge to the general public.

1.2.2 The centre which can accommodate a maximum of 150 occupants, including 120 students, 20 residential staff and 10 non-residential staff. The entire centre is to be developed in phases. The phase one development consists of male and female dormitories with communal toilets and showers, administration office and E&M plant rooms and the phase two development consists of assembly hall, function rooms, kitchen, canteen, and more dormitories.

1.2.3 Since there is no public sewage connection to the centre, a sewage treatment plant (hereinafter called "STP") is constructed to ensure water quality of treated effluent complies with the Water Pollution Control Ordinance (WPCO) discharge licence requirement. This STP is provided under phase one development. Capacity of the STP is duly designed at 37 m³/day to serve the entire centre when it is fully occupied.

1.2.4 In view of good quality of treated effluent complying with EPD discharge standard and for environmental protection reason, part of treated effluent will undergo further treatment and reused for toilet flushing within the boundary of the Vipassana Meditation Centre (hereinafter called “VMC”). The construction and operation of the treated sewage effluent (hereinafter called “TSE”) reuse system will be provided after both phase one and phase two development of VMC are completed. Potable water

consumption can be reduced with the operation of the TSE reuse system, and this will contribute to a green and sustainable environment.

- 1.2.5 The anticipated water consumption from TSE reuse system for toilet flushing is provided in **Table 1**.

Table 1: Anticipated Water Consumption from TSE Reuse System

Plant Location	Toilet Flushing (m ³ /day)
VMC STP	20

1.3 Name of Project Proponent

Hong Kong Vipassana Meditation Centre Limited (HKVMC)

1.4 Location and Scale of Project

- 1.4.1 The TSE reuse system will be installed within the boundary of VMC at Lot No. 146 in D.D.319, Tung Wan, Lantau Island (see **Figure 1**). Dedicated access path for vehicles and pedestrians from main entrance of VMC to STP is provided for delivery of materials. The TSE reuse system is designed for a maximum handling capacity of 20 m³/day for toilet flushing. The TSE reuse system will be located within the STP (see **Figure 2**).
- 1.4.2 The TSE reuse system will comprise a sodium hypochlorite (NaOCl) dosing system, effluent holding tank #2, two transfer pumps, a flushing tank together with associated piping network (see **Figure 3**). The equipment will occupy a footprint of around 20 m² within the STP and the water distribution pipeline for toilet flushing will be less than 100 mm in diameter and around 200 m long.
- 1.4.3 The TSE reuse system is designed for unmanned operation on 24 hours a day basis. During normal operation, treated effluent from STP will flow from effluent holding tank #1 to effluent holding tank #2; the NaOCl dosing system will dose 10% NaOCl solution into effluent holding tank #2 for further disinfection; and the treated effluent will be transferred to the flushing tank and the associated piping network for toilet flushing.
- 1.4.4 The TSE reuse system will only involve minor mechanical and electrical installation works within the boundary of VMC. There should not be any additional site clearance, site formation or large scale excavation works involved during the construction and operation of the TSE reuse system.

Adjacent sensitive receivers of VMC are shown in **Figure 4**.

1.5 Number and Types of Designated Project Covered by this Project Profile

Reuse of treated effluent from STP for toilet flushing is identified as a Designated Project in accordance to Item F.4, Part I, Schedule 2 – “An activity for the reuse of treated sewage effluent from a treatment plant” of the Environmental Impact Assessment Ordinance (EIAO).

1.6 Name and Telephone Number of Contact Person

Name: Mr. Chris Lam
Capacity: Project Manager of Dunwell Engineering Co., Ltd
Tel: 2443 8171
Address: 8 Wang Lee Street, Yuen Long Industrial Estate, Yuen Long, N.T.

2 OUTLINE OF PLANNING AND IMPLEMENTATION PROGRAMME

2.1 Project Planning and Implementation

STP sub-contractor, Dunwell Engineering Co., Ltd., is responsible for the design and construction of STP and TSE reuse system, applying for the WPCO discharge licence and environmental permit and providing training to the operator. HKVMC, on the other hand, is responsible for supervising the construction and operation of VMC.

2.2 Program for TSE Reuse System Installation

Phase one development of VMC was completed in August 2016 and phase two development of VMC was completed in February 2018. It is anticipated that the construction of the TSE reuse system will commence in early 2020 and the whole system will be put into operation after testing and commissioning. Current WPCO discharge licence for the STP will be revised accordingly once the environmental permit for the proposed TSE reuse system is granted.

3 MAJOR ELEMENTS OF THE SURROUNDING ENVIRONMENT

3.1 Existing and Planned Sensitive Receivers

The representative sensitive receivers (SR) in the vicinity of the TSE reuse system at VMC are listed in **Table 2** and their locations are shown in **Figure 4**.

Table 2: Representative Sensitive Receivers in the Vicinity of TSE Reuse System at VMC

SR No.*	Description	Type of Use	No. of Storey	Distance between SR and Plant Boundary (m)
ANSR1	Mok Law Shui Wah School	Institution & Residential	1	100
ANSR2	HK Red Cross Shek Pik Youth Camp	Recreational	1	250
WSR3	Shek Pik Reservoir	Reservoir	N.A.	1000
WSR4	Tung Wan	Beach	N.A.	500
ANSR5	CSD Staff Quarters	Residential	1	1000
WSR6	Natural Stream	Stream	N.A.	50
ANSR7	Lantau South Country Park	Recreational	N.A.	100
SR8	Rock Carving at Shek Pik, Lantau Island	Declared Monument	N.A.	800
SR9	Tung Wan Site of Archaeological Interest, Shek Pik	Site of Archaeological Interest	N.A.	250

* Remarks: ANSR denotes “Air & noise sensitive receiver”
WSR denotes “Water sensitive receiver”

3.1.1 Air Quality and Noise

Mok Law Shui Wah School (ANSR1) located to the north (about 100 m from VMC), Hong Kong Red Cross Shek Pik Youth Camp (ANSR2) located to the northwest (about 250 m from VMC), CSD Staff Quarters (ANSR5) located to the northwest (about 1000 m from VMC), Lantau South Country Park (ANSR7) located to the north (about 100 m from VMC) are identified as air and noise sensitive receivers during the construction and operation stages.

3.1.2 Water Quality

Shek Pik Reservoir (WSR3) to the north (about 1000 m from VMC), Tung Wan (WSR4) located the southwest (about 500 m from VMC) and Natural Stream (WSR6) located to the northwest (about 50 m from VMC) are identified as water sensitive receivers during the construction and operation stages.

3.1.3 Cultural Heritage

Rock Carving at Shek Pik, Lantau Island (SR8) located to the northwest (about 800 m from VMC) and Tung Wan Site of Archaeological Interest, Shek Pik (SR9) located to the northwest (about 250 m from VMC) are defined as cultural heritage sensitive receivers during the construction and operation stages.

3.1.4 Health and Hygiene

Users of VMC including students, staff and visitors are identified as sensitive receivers during the operation stage.

4 POSSIBLE IMPACTS ON THE ENVIRONMENT

4.1 Possible Environmental Impacts during Construction Stage

4.1.1 Air Quality

Given the small scale of electrical and mechanical works involving the installation of chemical dosing system, two transfer pumps, a few water tanks and associated distribution pipe work, no adverse air quality impact is expected during the construction stage.

4.1.2 Noise

Construction noise would be generated mainly from equipment installation within the STP and associated pipeline connection within the boundary of VMC. In view of the small scale of the project, adverse construction noise impact even to the closest noise sensitive receiver Mok Law Shui Wah School (ANSR1) would not be anticipated.

4.1.3 Water Quality

No site runoff and wastewater would be generated from the construction of

the TSE reuse system, hence adverse water quality impact to Tung Wan (WSR4) and the nearby Natural Stream (WSR6) during the construction stage is not anticipated.

4.1.4 Waste

There will be negligible amount of solid waste produced during the construction of the TSE reuse system. Waste to be generated includes small packing carton boxes for dosing pumps and some plastic bags for spare parts. All waste will be taken away by garbage trucks; therefore, adverse waste management impact is not anticipated during the construction stage.

4.1.5 Ecology

Relevant equipment installation and associated distribution pipe work would be located within the boundary of VMC. Adverse ecological impact to environment including adjacent Lantau South Country Park (ANSR7), Natural Stream (WSR6) and Tung Wan (WSR4) is not anticipated during the construction stage.

4.1.6 Landscape and Visual

A detailed tree survey was carried out before the construction of VMC. No trees will be cut down owing to construction of TSE reuse system. Also, relevant equipment installation and associated distribution pipe work would be located within the boundary of VMC and a new built road will be used to transport the materials in and out of the STP. Owing to the small scale of the project, the landscape and visual impact during the construction stage is negligible.

4.1.7 Health and Hygiene

Adverse impact on health and hygiene is not anticipated during the construction stage.

4.1.8 Cultural Heritage

Relevant equipment installation and associated distribution pipe work would be located within the boundary of VMC. Owing to large separation distance and the proposed works will be carried out within the boundary of VMC, adverse impact to both built heritage and archaeology including

Rock Carving at Shek Pik, Lantau Island (Declared Monument) (SR8) and Tung Wan Site of Archaeological Interest, Shek Pik (SR9) is not anticipated during the construction stage.

4.2 Possible Environmental Impacts during Operation Stage

4.2.1 Natural Resources

Currently the toilets inside VMC all utilize potable water for flushing activities. The use of reclaimed water under the proposed TSE reuse system will reduce the water demand for toilet flushing, especially during dry season. It is anticipated that a maximum of 20 m³/day of potable water can be saved due to the proposed TSE reuse system.

4.2.2 Air Quality

The TSE reuse system will be operated in enclosed STP consuming only electricity with no fuel combustion exhaust gases so there will be no gaseous air pollutants and fugitive dust particulate emissions during the operation. The sodium hypochlorite solution will be stored in a covered tank within the STP and the operation of the TSE reuse system itself will not produce any odour, so there will not be any potential odour nuisance generated from the operation of the TSE reuse system. In addition, a deodourizing unit was installed as part of the STP to remove odour generated inside the plant room. Since additional equipment of the proposed TSE reuse system will be installed inside the STP and there will not be any change to the existing plant room area, the existing deodourizing unit is considered sufficient to treat any odour generated during the wastewater treatment process. Adverse impact to nearby air sensitive receivers including Mok Law Shui Wah School (ANSR1) and Hong Kong Red Cross Shek Pik Youth Camp (ANSR2) is not anticipated during the operation stage.

4.2.3 Noise

The two transfer pumps will be the main potential noise source during the operation of the TSE reuse system. However, in view of low power rating of pumps and the equipment will be installed inside the STP at lower level of VMC with good enclosure, noise arising from the TSE reuse system is anticipated to be well controlled such that even the closest noise sensitive receiver Mok Law Shui Wah School (ANSR1) would not detect any noise

during the operation stage.

4.2.4 Water Quality

During operation stage, the treated effluent from STP will flow from effluent holding tank #1 to effluent holding tank #2. The 10% NaOCl solution will be dosed to effluent holding tank #2. The treated water quality of the TSE reuse system is shown in **Table 3**.

Table 3: Treated Water Quality of TSE Reuse System

Water Quality Parameter	Unit	USEPA Criteria Urban Reuse (Unrestricted) *	Treated Water Quality of the TSE Reuse System
pH	-	6-9	6-9
Biochemical Oxygen Demand (BOD ₅)	mg/L	≤ 10	≤ 10
Turbidity	NTU	≤ 2	≤ 2
Fecal Coliform	No./100mL	Not Detectable	Not Detectable
Total Residual Chlorine	mg/L	≥ 1	≥ 1 **

Remarks:

* From Table 4-4 of USEPA (2012) Guidelines for Water Reuse

** The proposed dosing of NaOCl should be determined subject to actual effluent quality prior to commissioning in order to maintain the specific residual chlorine level. The required dosing of NaOCl should also be reviewed through the monitoring mechanism as stated in Clause 5.2.3.

Reclaimed water from the TSE reuse system will follow the USEPA criteria for Urban Reuse (Unrestricted). In addition, it will have an overall better water quality than the existing WPCO discharge licence requirement. Since the treated effluent from effluent holding tank #1 will not be dosed with the 10% NaOCl solution, it will not affect the nearby sensitive receivers such as the Natural Stream (WSR6) and Tung Wan (WSR4). No adverse water quality impact is expected during the operation of the TSE reuse system.

4.2.5 Waste

During operation phase, sludge generated from the wastewater treatment process will be recycled back to the anoxic tank for biological degradation. Excess sludge will be stored inside the sludge holding tank and tankered-away to nearby sewage treatment works if required. No adverse waste management impact is expected during the operation.

4.2.6 Ecology

Part of the treated effluent from the STP will be further processed at the TSE reuse system while the remaining will be discharged to the surface u-channel leading to the Natural Stream (WSR6) and Tung Wan (WSR4). Since treated effluent from the STP should comply with the WPCO discharge licence requirement, no adverse ecology impact is anticipated during the operation of the TSE reuse system.

4.2.7 Health and Hygiene

All treated effluent from the STP should be disinfected with UV lights and sodium hypochlorite prior to reuse. Since the treated water from TSE reuse system for toilet flushing is for non-potable use, the impact on human health and hygiene is minimal. However, potential health and hygiene concerns may exist if there is incorrect connection of the potable and reclaimed water pipes.

4.2.8 Hazard to Life

50% sodium hydroxide solution (50L) for pH adjustment and 10% sodium hypochlorite solution (200L) for disinfection will be used for the operation of the STP and the TSE reuse system. Sodium hydroxide is classified as Category 3 corrosive substance under the Dangerous Goods Ordinance (Cap 295). It is hazardous in case of skin contact or eye contact. Sodium hypochlorite is classified as Category 4 poisonous substance under the Dangerous Goods Ordinance (Cap 295). It will liberate toxic gas if it is accidentally mixed with incompatible chemicals. In fact, if sodium hydroxide mixes with sodium hypochlorite, only heat, but not toxic gas, would be evolved. The small amount of sodium hydroxide and sodium hypochlorite solutions stored on site is within Fire Services Department dangerous goods exemption quantity. Also, they would not constitute potentially hazardous installations in accordance with HKPSG Chapter

12.4. As such, no hazard impact is anticipated during the operation of the TSE reuse system.

4.2.9 Landscape and Visual

Since relevant equipment installation and associated distribution pipe work would be located within the boundary of VMC, the landscape and visual impact is anticipated to be insignificant during the operation stage.

4.2.10 Cultural Heritage

The treated effluent from STP will be discharged to the surface u-channel leading to the Natural Stream (WSR6) and Tung Wan (WSR4). However, the treated effluent would not pass through built heritage nor site of archaeological interest; hence, no adverse cultural heritage impact is anticipated during the operation stage.

5 ENVIRONMENTAL PROTECTION MEASURES TO BE INCORPORATED

5.1 Environmental Protection Measures during Construction Stage

5.1.1 Air Quality

As discussed in Section 4, no adverse air quality impact due to construction of TSE reuse system will be anticipated.

5.1.2 Noise

Implementation of good site practices e.g. regular maintenance of powered mechanical equipment and use of silent equipment as the proper noise control measures are recommended to minimize the potential noise impact during the construction stage.

5.1.3 Water Quality

There will be no site runoff and wastewater generated from the construction of TSE reuse system.

5.1.4 Waste

There will be negligible amount of solid waste produced from the construction of the TSE reuse system. The waste will be taken away by

garbage trucks and disposed of at nearby refuse collection point or refuse transfer station.

5.2 Environmental Protection Measures during Operation Stage

5.2.1 Air Quality

The sodium hypochlorite solution will be stored in a covered tank within the STP and the operation of the TSE reuse system itself will not produce any odour, so there will not be any potential odour nuisance generated from the operation of the TSE reuse system. In addition, a deodourizing unit was installed as part of the STP to remove odour generated inside the plant room. Since additional equipment of the proposed TSE reuse system will be installed inside the STP and there will not be any change to the existing plant room area, the existing deodourizing unit is considered sufficient to treat any odour generated during the wastewater treatment process. No adverse impact to the nearby sensitive receivers is anticipated during the operation stage.

5.2.2 Noise

Equipment will be enclosed to contain any noise generated from the operation. Also, acoustic door and air duct silencer are adopted. It is believed above measures are sufficient in reducing noise transmission out of the plant room.

5.2.3 Water Quality

A program should be set up for monitoring the water quality from the TSE reuse system to ensure compliance with the quality standards specified in **Table 3**. Water sample will be withdrawn from flushing tank weekly for pH and total residual chlorine testing by rapid test kits. In addition, water sample will be withdrawn from the flushing tank monthly for turbidity, BOD₅ and fecal coliform testing by HOKLAS accredited laboratory (or other international accredited laboratory that is HOKLAS-equivalent). Should exceedance of water quality standard be found, the TSE reuse system will be suspended immediately. The TSE reuse system will be resumed only when the quality of water sample is tested and complies with the requirement stated in **Table 3**. In addition, in order to promote the treated water quality from TSE reuse system, the flushing tank will be cleaned at least once every six months.

5.2.4 Waste

There will be negligible amount of sludge produced from the wastewater treatment process. Excess sludge will be stored inside the sludge holding tank and tankered-away to nearby sewage treatment works if required.

5.2.5 Health and Hygiene

The treated water pipeline system will be a separate system and will not be connected with the potable water pipeline system. To avoid cross-connection of the treated water supply to the potable water supply, the treated water pipes will be colour-coded and clearly labeled with warning signs so that physical connection of the treated water pipes with potable water fittings would not be possible.

5.2.6 Hazard to Life

A new built road to the entrance of VMC was completed under phase one of the development so sodium hydroxide and sodium hypochlorite solutions can be delivered to the STP directly by truck. The chemical will be stored in enclosed tank and protected by drip tray. The sodium hydroxide solution will be kept below 50L in storage and the sodium hypochlorite solution will be kept below 250L in storage not exceeding the exempted quantity under the Dangerous Goods Ordinance (Cap. 295) and its subsidiary Regulations. During normal operation, staff will be required to wear personal protective gears, including hand gloves, face mask and apron to prevent direct contact with the chemical while working inside the STP. An emergency plan will also be developed for the operation of the TSE reuse system.

5.3 Comments on Environmental Effects

The use of treated water for toilet flushing will reduce the quantity of potable water consumed in VMC. This is considered to be benefits or positive impacts of the project. The promotion of the use of treated water in appropriate circumstances to enable conservation of potable water will contribute to a green and sustainable environment in Hong Kong.

6 USE OF PREVIOUSLY APPROVED REPORTS

6.1.1 Reference is made to similar projects making direct application of an

Environmental Permit under Item F.4, Part I, Schedule 2 of the EIAO in **Table 4**.

Table 4: Previous Application for Permission to Apply Directly for Environmental Permit

Application No.	Project Title	Approval Date
DIR-177/2009	Water Reclamation Facilities in Shatin Sewage Treatment Works	26-Jun-2009
DIR-182/2009	Water Reclamation Facilities for Yuen Long, Sai Kung and Stanley Sewage Treatment Works	12-Aug-2009
DIR-183/2009	Water Reclamation Facilities for Stonecutters Island, Siu Ho Wan and Sham Tseng Sewage Treatment Works	7-Aug-2009
DIR-214/2011	Water Reclamation Facility in Tai Po Sewage Treatment Works	28-Sep-2011

6.1.2 For the projects of (i) Water Reclamation Facilities in Shatin Sewage Treatment Works operated by DSD, (ii) Water Reclamation Facilities for Yuen Long, Sai Kung and Stanley Sewage Treatment Works operated by DSD, (iii) Water Reclamation Facilities for Stonecutters Island, Siu Ho Wan and Sham Tseng Sewage Treatment Works operated by DSD and (iv) Water Reclamation Facility in Tai Po Sewage Treatment Works operated by DSD previously, the performance of the facilities was satisfactory.

7 SUMMARY OF POTENTIAL ENVIRONMENTAL IMPACTS AND MITIGATION MEASURES

7.1.1 The potential environmental impacts and environmental mitigation measures of the TSE reuse system are summarized in **Table 5**.

Table 5: Summary of Potential Environmental Impacts & Mitigation Measures

Project Stage	Potential Environmental Impact	Mitigation Measures	Relevant Section in the Project Profile
Construction	Air quality	No adverse impact is identified; no mitigation measure is required.	4.1.1 & 5.1.1
	Minor noise impact	Implementation of good site	4.1.2 & 5.1.2

Project Profile - Reuse of Treated Sewage Effluent from a Treatment Plant at Hong Kong Vipassana Meditation Centre, Lantau Island

Project Stage	Potential Environmental Impact	Mitigation Measures	Relevant Section in the Project Profile
		practices e.g. regular maintenance of powered mechanical equipment and use of silent equipment as proper noise control measures.	
	Water quality	No adverse impact is identified; no mitigation measure is required.	4.1.3 & 5.1.3
	Minor waste management impact	The waste will be taken away by garbage trucks and disposed of at nearby refuse collection point or refuse transfer station.	4.1.4 & 5.1.4
	Ecological impact	No adverse impact is identified; no mitigation measure is required.	4.1.5
	Landscape and visual	No adverse impact is identified; no mitigation measure is required.	4.1.6
	Health and hygiene	No adverse impact is identified; no mitigation measure is required.	4.1.7
	Cultural heritage	No adverse impact is identified; no mitigation measure is required.	4.1.8
Operation	Impact on natural resources	Beneficial impact; no mitigation measure is required.	4.2.1
	Air quality	Sodium hypochlorite solution will be stored in a covered tank. A deodourizing unit was installed inside the STP to treat any odour generated from the wastewater	4.2.2 & 5.2.1

Project Profile - Reuse of Treated Sewage Effluent from a Treatment Plant at Hong Kong Vipassana Meditation Centre, Lantau Island

Project Stage	Potential Environmental Impact	Mitigation Measures	Relevant Section in the Project Profile
		treatment process.	
	Minor noise impact	Equipment will be enclosed to contain any noise emissions generated from the operation. Also, acoustic door and air duct silencer are adopted.	4.2.3 & 5.2.2
	Water quality	Water samples will be taken regularly. Should exceedance of water quality standard be found, the TSE reuse system will be suspended immediately. The flushing water tanks will be cleaned at least once every six months.	4.2.4 & 5.2.3
	Minor waste management impact	Excess sludge will be stored inside the sludge holding tank and tankered-away to nearby sewage treatment works if required.	4.2.5 & 5.2.4
	Ecological impact	No adverse impact is identified; no mitigation measure is required.	4.2.6
	Health and hygiene	To avoid cross-connection of the treated water supply to the potable water supply, the treated water pipes will be colour-coded and clearly labeled with warning signs.	4.2.7 & 5.2.5
	Hazard to life	The chemical will be transported to the STP in enclosed tank and the chemical tank will be protected by drip tray. Staff will be required to wear	4.2.8 & 5.2.6

Project Profile - Reuse of Treated Sewage Effluent from a Treatment Plant at Hong Kong Vipassana Meditation Centre, Lantau Island

Project Stage	Potential Environmental Impact	Mitigation Measures	Relevant Section in the Project Profile
		personal protective gears while working inside the STP.	
	Landscape and visual	No adverse impact is identified; no mitigation measure is required.	4.2.9
	Cultural heritage	No adverse impact is identified; no mitigation measure is required.	4.2.10

7.1.2 With proper implementation of the above environmental mitigation measures that will be incorporated into the TSE reuse system, insurmountable environmental impact during the construction and operation stages of the proposed TSE reuse system is not expected.

7.1.3 To conclude, the use of the treated effluent for toilet flushing has the advantages of (i) reducing the demand on potable water since it is a scarce resource deserved for preservation and (ii) reducing wastewater discharges from the STP and the pollution loading to the environment.

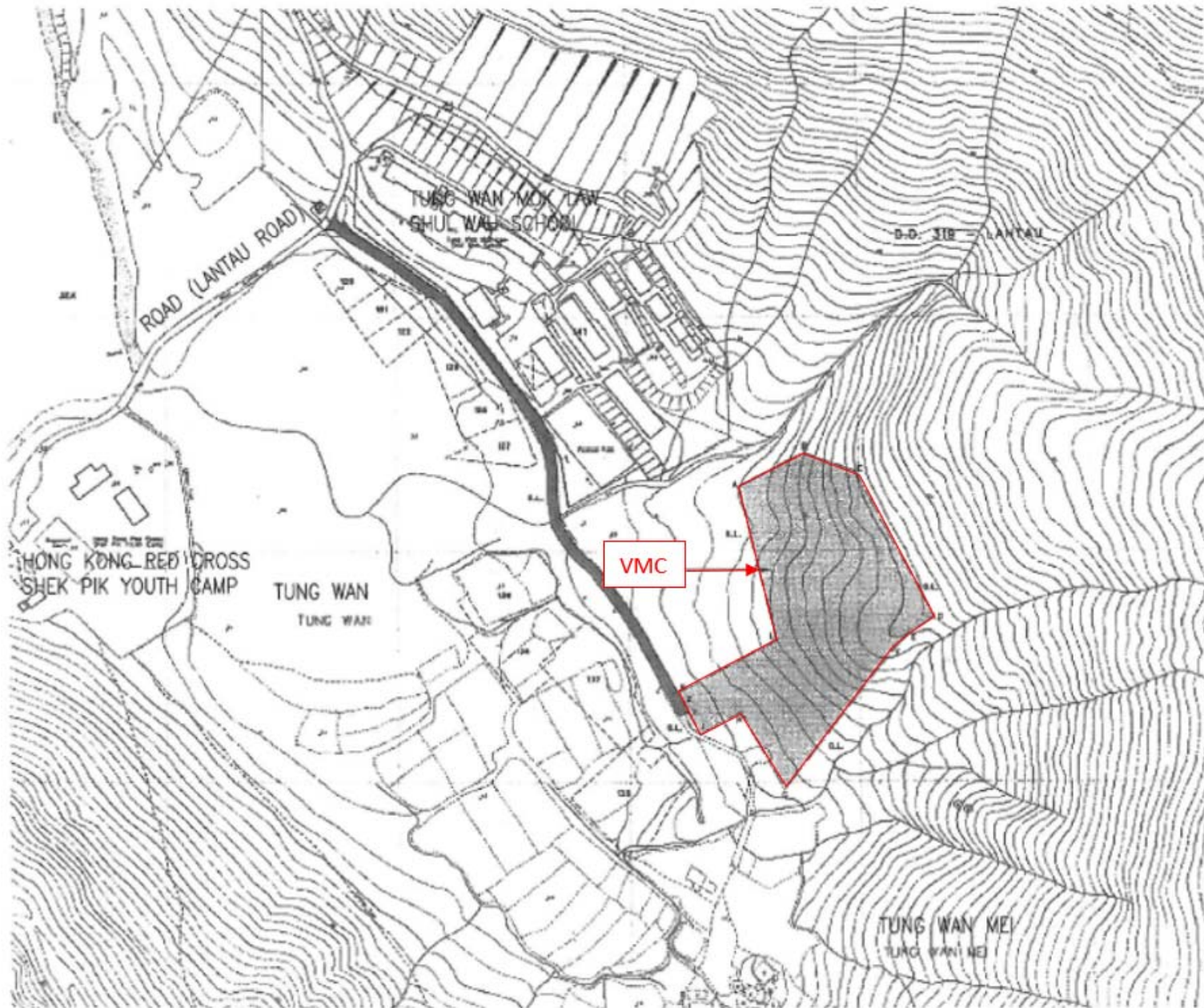
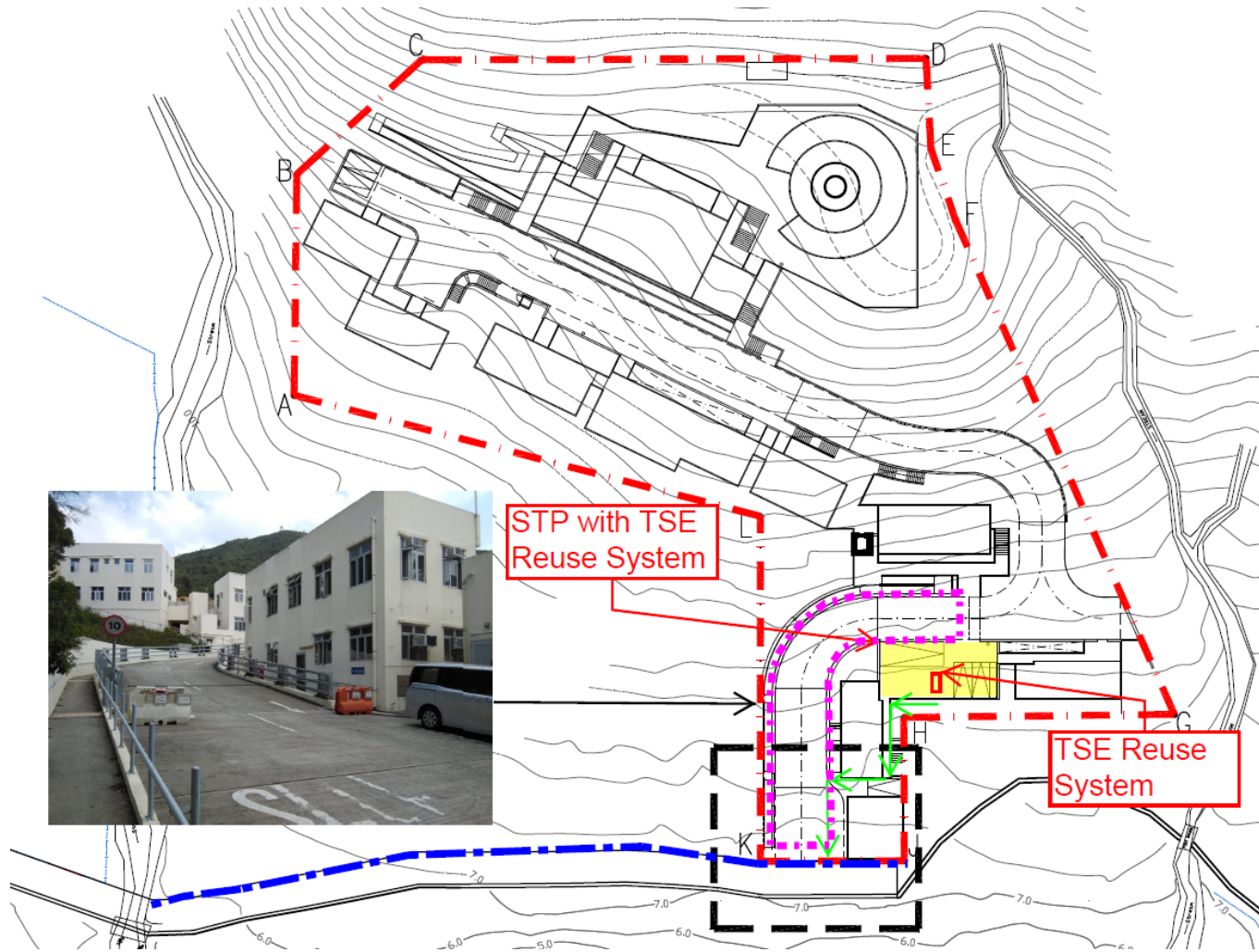

Figure 1: Site Location Plan of VMC







Legend:	
	Site Boundary
	Site Access Path
	Surface U-Channel
	STP Effluent Discharge Route

Figure 2: Site Layout Plan of VMC

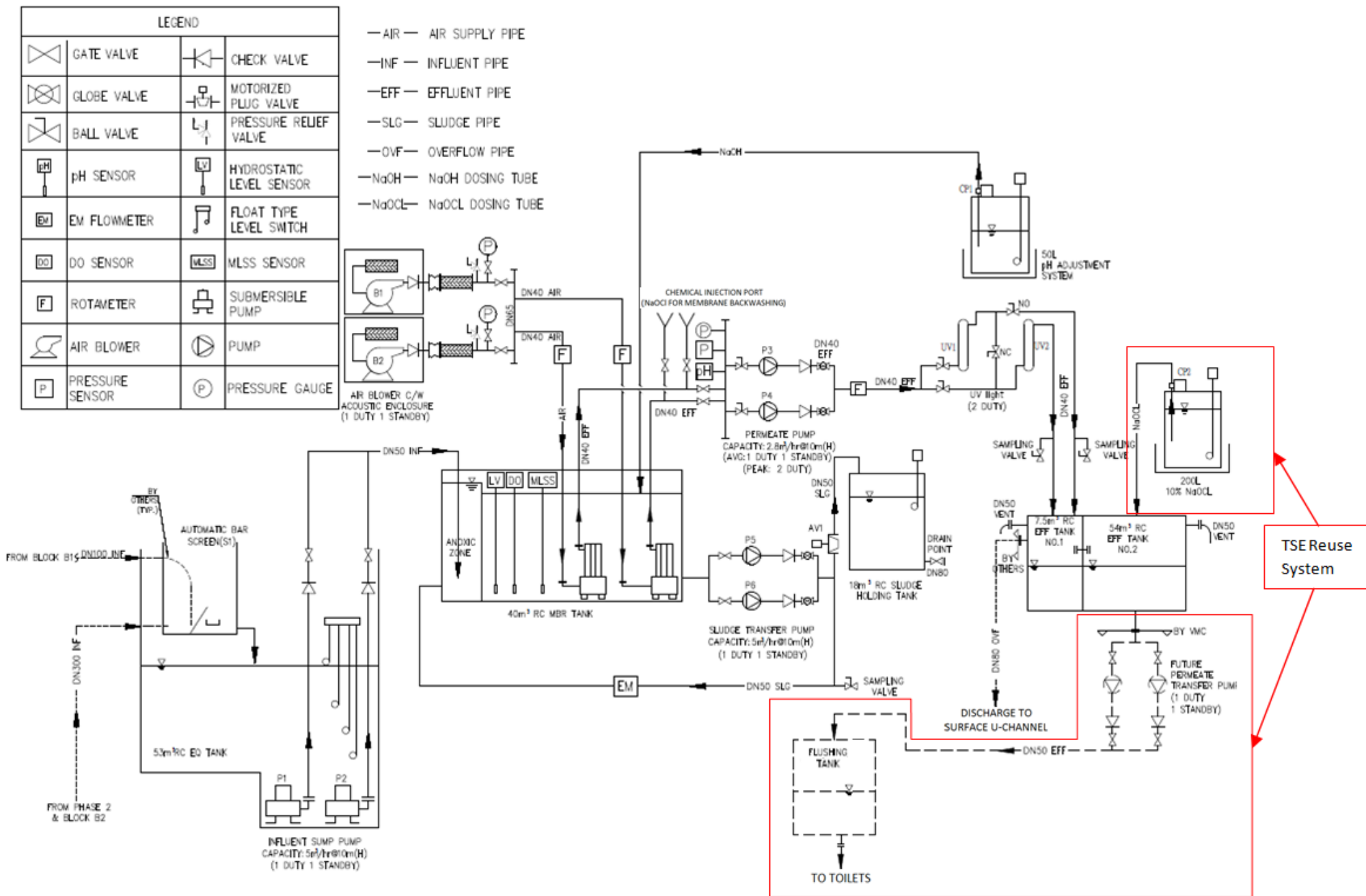

Figure 3: Process Flow Diagram of STP with TSE Reuse System

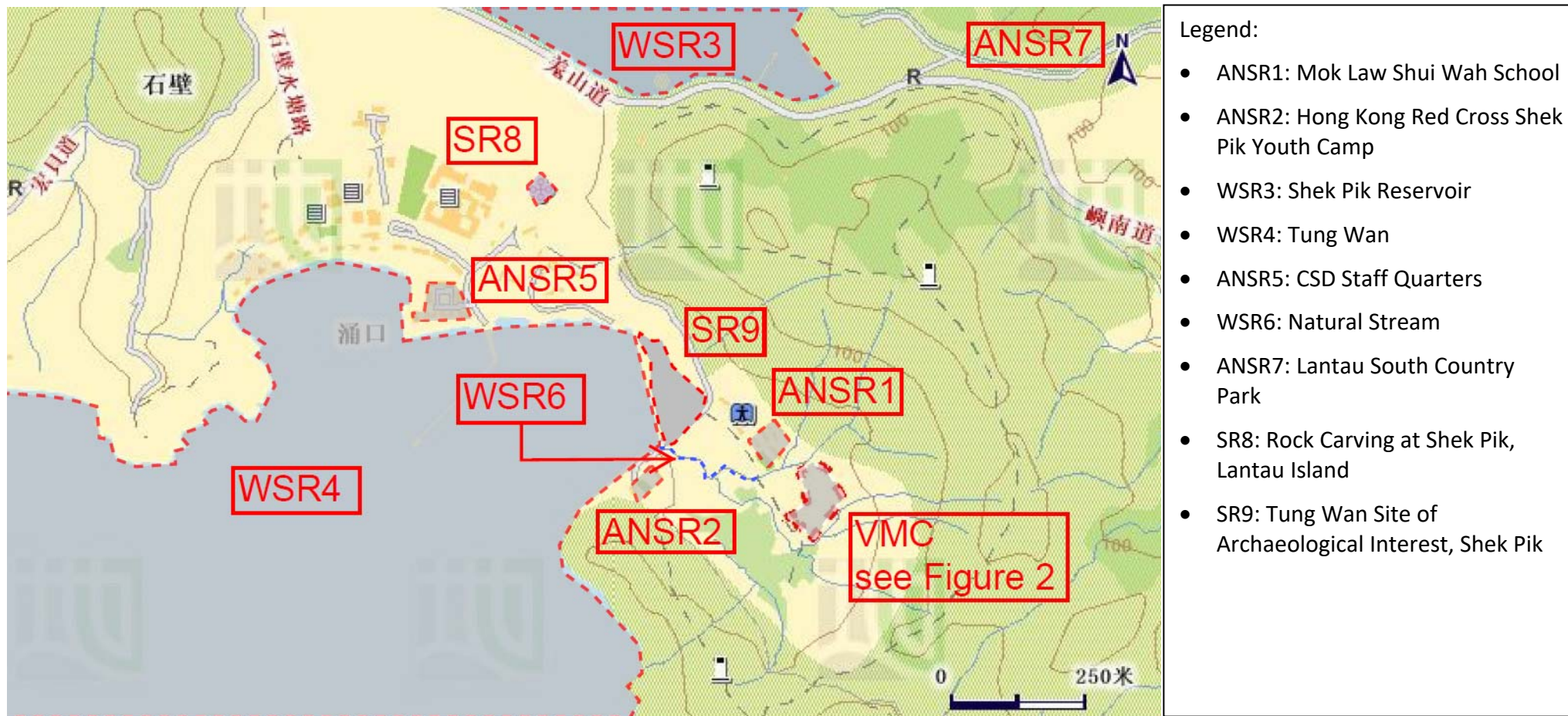

Figure 4: Adjacent Sensitive Receivers of VMC