

**Addendum: Technical
Guidelines for Minor Works
Items related to Subdivided Units**

3.24 Sub-Divided Units

MW Items	1.41	1.42
Simple Comparison of Descriptions	Erection of any non-load bearing block wall, laying of any solid floor screeding, or erection or alteration of any aboveground drain in a domestic flat;	Formation or alteration of any opening to the enclosure (other than a load bearing wall) of any staircase that is used as a means of escape or a means of access for firefighting and rescue or its protected lobby;
	No additional load to cantilevered slab.	Not involve alteration of structural elements.
	That is subdivided into, or that as a result of the works will be subdivided into, 3 or more rooms at least 3 of which - (i) are resulted from, or are affected by, an alteration of the layout of the flat; (ii) are provided with a lavatory basin, sink, water-closet fitment, shower or bath; and (iii) are intended as, or having regard to the size and layout of the rooms, are likely to be adapted as, places for sleeping;	
	in which the number of rooms falling within the description of paragraph(a)(ii) and (iii) is, or as a result of the works will be, greater than that as shown on the approved plan.	
Other considerations	<ul style="list-style-type: none"> ● B(C)R 90 & FS Code subsection C5 & clause C11.1 – Requirements of fire resisting construction. ● B(P)R 41 & FS Code subsection A8 – Means of escape. ● B(P)R 41A, 41B, 41C & 41D & FS Code subsection A10 – Means of access for firefighting and rescue. ● PNAP APP-86 – Design & construction of non-loadbearing partition walls. ● B(C)R & Code of Practice for Dead and Imposed Loads 2011. ● B(DW)R 10 – Not to overload the floor. ● B(DW)R 11 – Provision of precautionary measures from sudden collapse on cutting the steelwork. ● PNAP APP-21 – Provision of measures for public safety when carrying out demolition works. ● B(SSFPDWL)R 11 – Proper disposal of soil. ● B(SSFPDWL)R 24 & 25 – Provision of traps for soil & waste fitments. ● B(SSFPDWL)R 28 – Control of bends in soil & waste pipes. 	

	<ul style="list-style-type: none"> ● B(SSFPDWL)R 29, PNAP APP-93 & PNAP ADV-14 – Provision of access for repair & maintenance. ● B(SSFPDWL)R 34 – Control of the materials for pipes. ● PNAP APP-133 – Using cast iron pipes of acceptable performance requirements / standards. ● Agreement from the IO / co-owners of the external wall / roof (if being common part) should be sought.
--	---

B(C)R represents Building (Construction) Regulations; B(P)R represents Building (Planning) Regulations; FS Code represents Code of Practice for Fire Safety in Buildings 2011; PNAP represents Practice Notes for Authorized Persons, Registered Structural Engineers & Registered Geotechnical Engineers; B(DW)R represents Building (Demolition Works) Regulations & B(SSFPDWL)R represents Building (Standards of Sanitary Fittings, Plumbing, Drainage Works and Latrines) Regulations.

MW Items	1.43	3.39	3.40	
Simple Comparison of Descriptions	Erection of any non-load bearing block wall.			
	No additional load to cantilevered slab;			
	Not involve alteration of structural elements;			
	domestic flat or non-domestic flat	domestic flat	non-domestic flat	
	aggregate length of any additional wall per m ² of the floor area of the flat is			
	> 0.1 m for domestic flat or > 0.2 m for non-domestic flat;	> 0.1m, but ≤ 0.3m	> 0.2m, but ≤ 0.4m.	
		density of the wall ≤ 650 kg per m ³		
		height of the wall		
		≤ 3 m;	≤ 3.5 m;	
		thickness of the wall		
≤ 75 mm;		≤ 100 mm;		
thickness of the floor slab supporting the wall				
≥125 mm;				
thickness of the floor screeding of the floor slab supporting the wall ≤ 25 mm				
not fall within the item 3.39 or 3.40.				
Other considerations	<ul style="list-style-type: none"> ● B(C)R 90 & FS Code subsection C5 & clause C11.1 – Requirements of fire resisting construction. ● B(P)R 41 & FS Code subsection A8 – Means of escape. ● PNAP APP-86 – Design & construction of non-loadbearing partition walls. ● B(C)R & Code of Practice for Dead and Imposed Loads 2011. 			

B(C)R represents Building (Construction) Regulations; B(P)R represents Building (Planning) Regulations; FS Code represents Code of Practice for Fire Safety in Buildings 2011 & PNAP represents Practice Notes for Authorized Persons, Registered Structural Engineers & Registered Geotechnical Engineers.

MW Items	1.44	3.41	3.42	
Simple Comparison of Descriptions	Thickening of any floor slab in a flat by laying solid screeding.			
	No additional load to cantilevered slab;			
	domestic flat or non-domestic flat	domestic flat	non-domestic flat	
		If any non-load bearing block wall is erected in the flat, aggregate length of any additional wall per m ² of the floor area of the flat is		
		< 0.1m;	< 0.2m;	
		Compiled with the conditions in item		
		3.39(a), (b), (c), (d), (e) and (f)	3.40(a), (b), (c), (d) and (e)	
		density of the screeding ≤ 650 kg per m ³ ;		
		thickness of the floor slab supporting the wall		
		≥125 mm;		
thickness of the screeding				
> 25 mm	> 25 mm, but ≤ 75mm;	> 25 mm, but ≤ 125mm;		
	(if the aggregate area of the screeding is not more than 1.5 m ² within a floor area of 10 m ² of the flat and the nearest horizontal distance between each of the area of screeding is not less than 2 m) more than 25 mm but not more than 150 mm measured from the structural floor level.	(if the aggregate area of the screeding is not more than 2.5 m ² within a floor area of 10 m ² of the flat and the nearest horizontal distance between each of the area of screeding is not less than 2 m) more than 25 mm but not more than 150 mm measured from the structural floor level.		
not fall within the item 3.41 or 3.42.				
Other considerations	<ul style="list-style-type: none"> B(C)R & Code of Practice for Dead and Imposed Loads 2011. 			

B(C)R represents Building (Construction) Regulations.

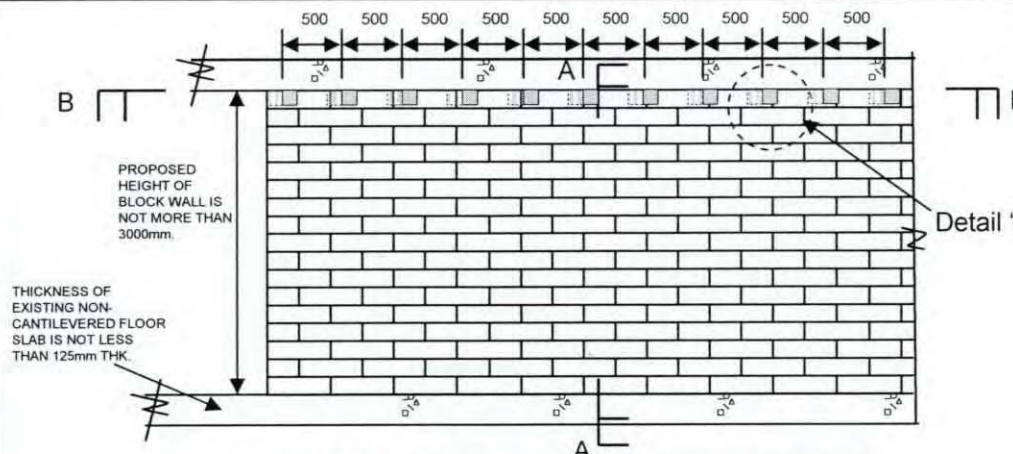

ERECTION / ALTERATION OF ANY NON-LOAD BEARING BLOCK WALL (OTHER THAN AN EXTERNAL BLOCK WALL)

GENERAL NOTES:

- The works carried out shall comply with the Buildings Ordinance and the provisions of other enactments. (Reference can be made to the examples listed in Sections 3 and 10 of the Guidelines.)
- All works shall comply with the following COP/ Standards:
 - Building (Construction) Regulations.
 - BS 5628 – Code of Practice for the Use of Masonry : Part 1 Structural use of Unreinforced Masonry.
 - Specifications and Method Statement for YTONG AAC Block Walls or their equivalent.
- Existing concrete grade is assumed to be Grade 30.
- All YTONG AAC blocks or their equivalent shall comply with BS6073-1 as solid block with the minimum compressive strength of 4 N/mm² and the density not more than 650 kg/m³.
- Mortar designation shall be Class (ii) to Table 1 of BS5628-1 with the mean compressive strength at 28 days of 4.5 N/mm² by site tests.

PREPARATION WORK:

- Obtain the relevant approved plans to ascertain the slab thickness and internal layout of the flat and that there are no unauthorized building works in the vicinity of the works.
- Carry out condition survey of the parent structure / existing condition prior to the commencement of works.

WORKING PROCEDURES:

- Install the required non - load bearing block wall as per the drawing.
- Make good and reinstate the affected areas of the parent building.
- Clean the site.
- Verify that the aggregate length of any additional block wall per m² of the floor area of the flat on which the wall is located is more than 0.1m but not more than 0.3m.

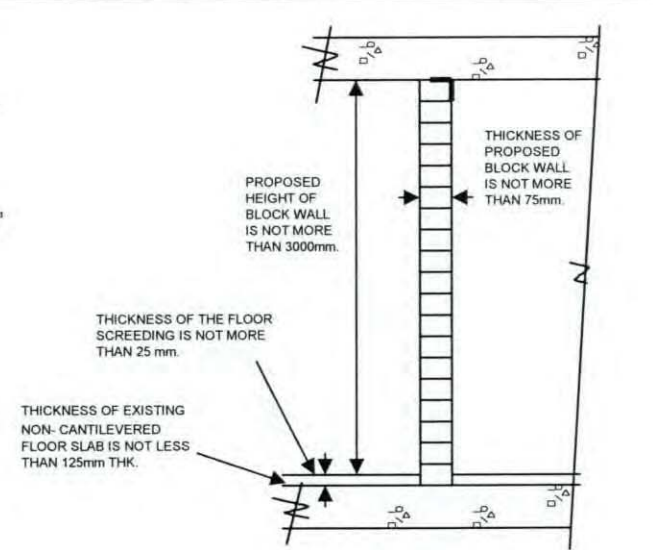

SECTION 'A-A'

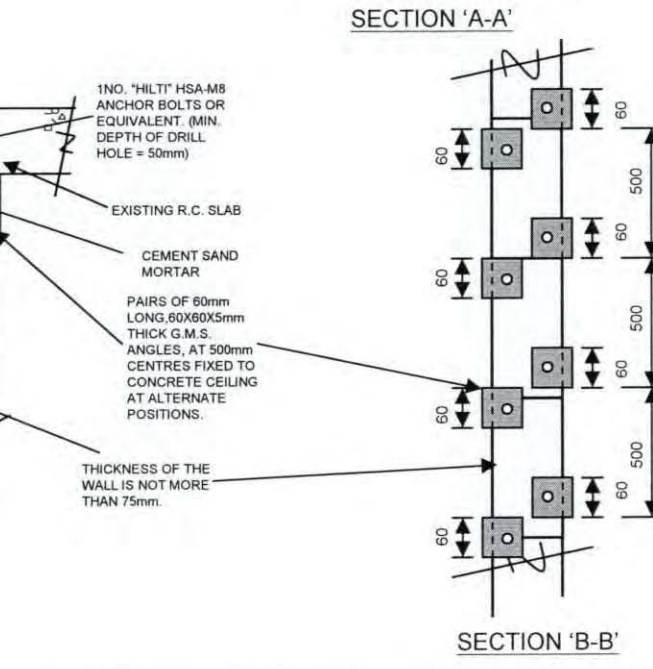

SECTION 'B-B'

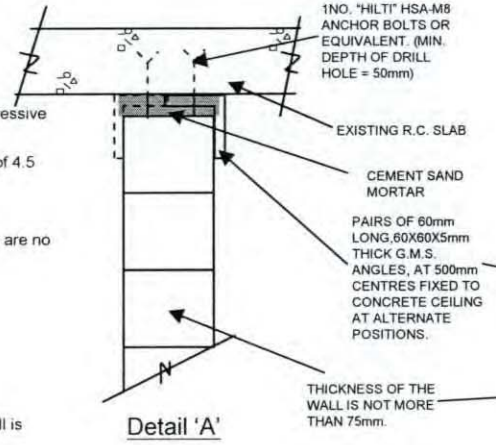

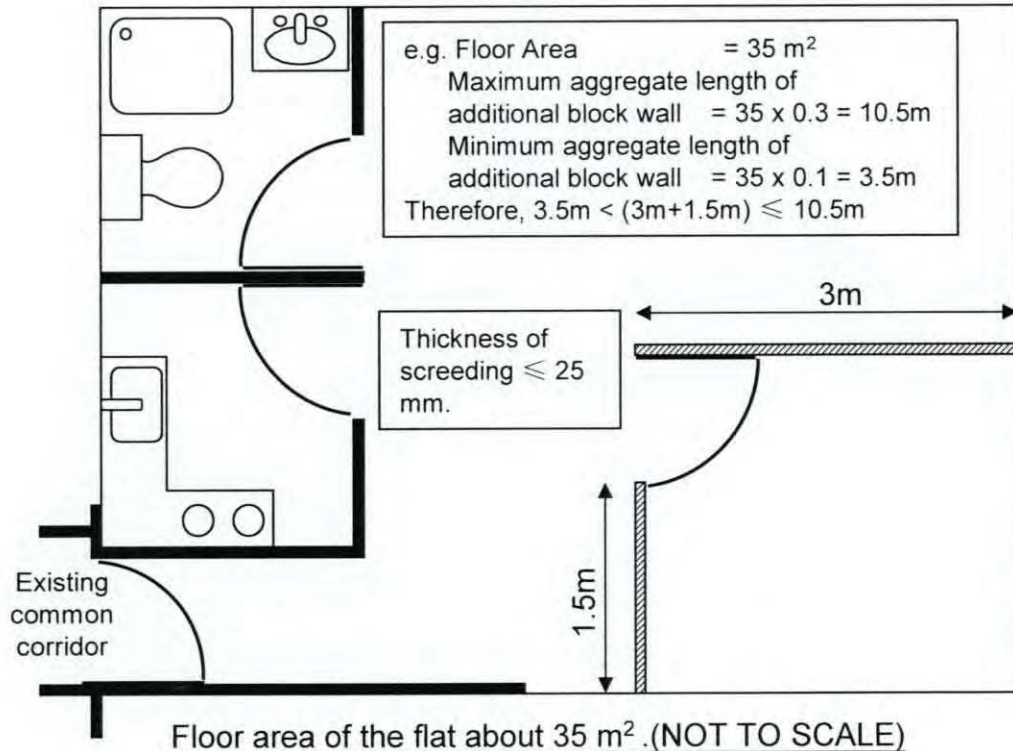

Detail 'A'

MINOR WORKS ITEM 3.39	ERECTION OF ANY NON-LOAD BEARING BLOCK WALL (OTHER THAN AN EXTERNAL BLOCK WALL) IN A DOMESTIC FLAT	SHEET 1 OF 2
------------------------------	---	---------------------



LEGEND:

 NON-LOAD BEARING WALL SHOWN ON APPROVED PLAN



 NON-LOAD BEARING BLOCK WALL AFTER THE MINOR WORKS ITEM 3.39 IS CARRIED OUT

*The aggregate length of any additional block wall per m² of the floor area of the flat on which the wall is located is more than 0.1m but not more than 0.3m.

Note:

1. Additional block wall is not more than 0.1m per m² of the floor area of the flat and floor screeding not more than 25mm thick measured from the structural floor level are exempted works.
2. Aggregate length of any additional wall means the difference between the total length of the non-load bearing walls (excluding the width of any door openings on the walls) in a flat as shown on the approved plan and that as measured after the minor works item is carried out.
3. The wall finishes are not counted in the wall thickness.

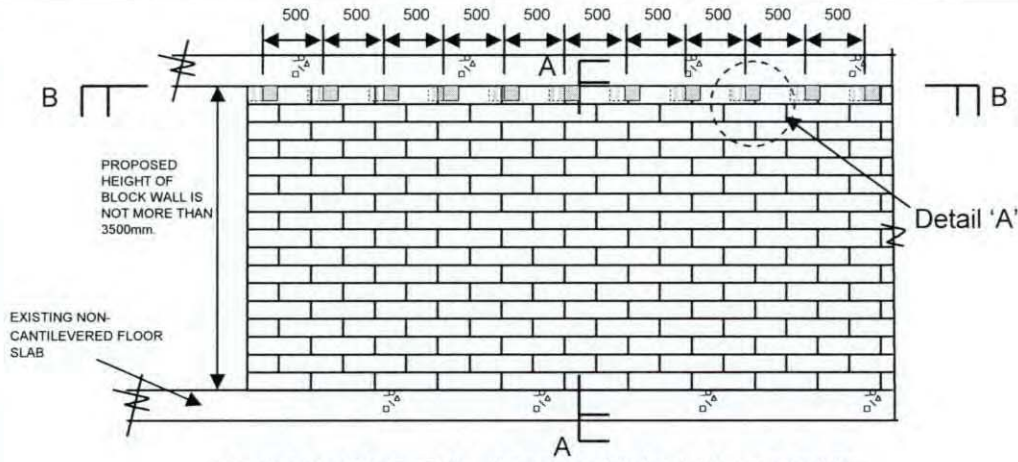
MINOR WORKS ITEM 3.39	ERECTION OF ANY NON-LOAD BEARING BLOCK WALL (OTHER THAN AN EXTERNAL BLOCK WALL) IN A DOMESTIC FLAT	SHEET 2 OF 2
-----------------------	--	--------------



**ERECTION / ALTERATION OF ANY NON-LOAD BEARING
BLOCK WALL (OTHER THAN AN EXTERNAL BLOCK WALL)**

GENERAL NOTES :

1. The works carried out shall comply with the Buildings Ordinance and the provisions of other enactments. (Reference can be made to the examples listed in Sections 3 and 10 of the Guidelines.)
2. All works shall comply with the following COP/ Standards:
 - Building (Construction) Regulations
 - BS 5628 – Code of Practice for the Use of Masonry : Part 1 Structural use of Unreinforced Masonry.
 - Specifications and Method Statement for YTONG AAC Block Walls or their equivalent.
3. Existing concrete grade is assumed to be Grade 30.
4. All YTONG AAC blocks or their equivalent shall comply with BS6073-1 as solid block with the minimum compressive strength of 4 N/mm² and the density not more than 650 kg/m³.
5. Mortar designation shall be Class (ii) to Table 1 of BS5628-1 with the mean compressive strength at 28 days of 4.5 N/mm² by site tests.

PREPARATION WORK:

1. Obtain the relevant approved plans to ascertain the slab thickness and internal layout of the flat and that there are no unauthorized building works in the vicinity of the works.
2. Carry out condition survey of the parent structure / existing condition prior to the commencement of works.

WORKING PROCEDURES:

1. Install the required non - load bearing block wall as per the drawing.
2. Make good and reinstate the affected areas of the parent building.
3. Clean the site.
4. Verify that the aggregate length of any additional block wall per m² of the floor area of the flat on which the wall is located is more than 0.2m but not more than 0.4m.

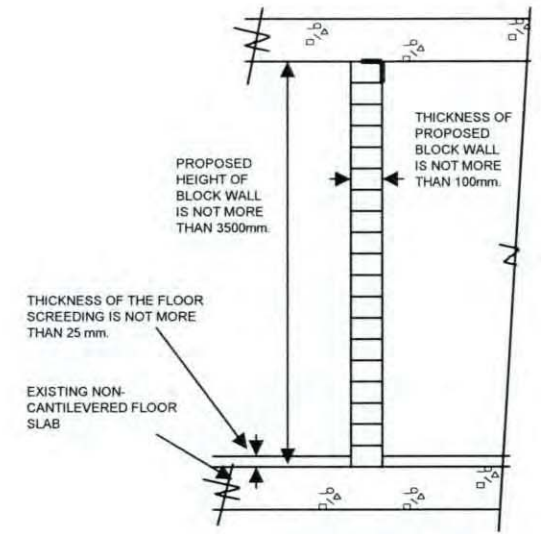

SECTION 'A-A'

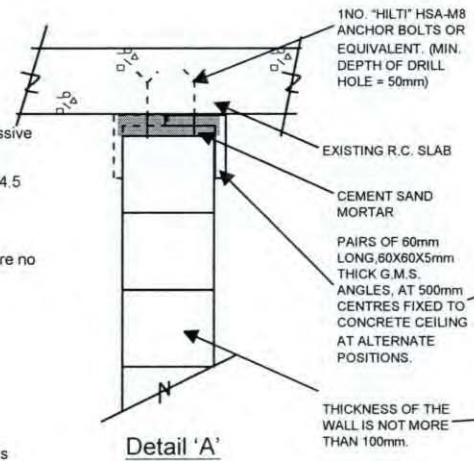

Detail 'A'

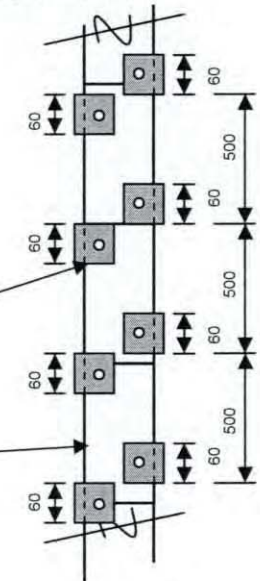

SECTION 'B-B'

MINOR WORKS ITEM 3.40	ERECTION OF ANY NON-LOAD BEARING BLOCK WALL (OTHER THAN AN EXTERNAL BLOCK WALL) IN A NON - DOMESTIC FLAT	SHEET 1 OF 2
------------------------------	---	---------------------

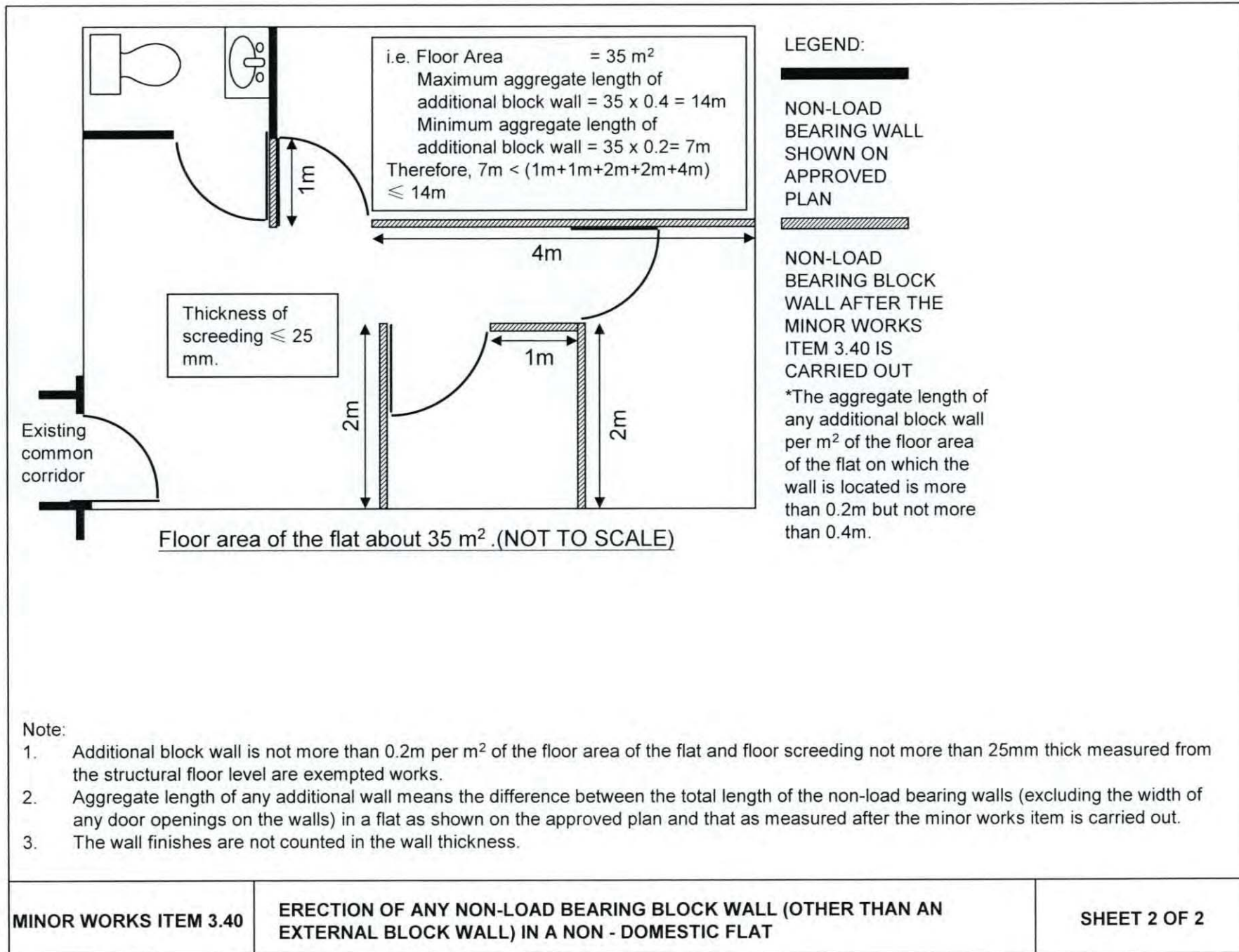

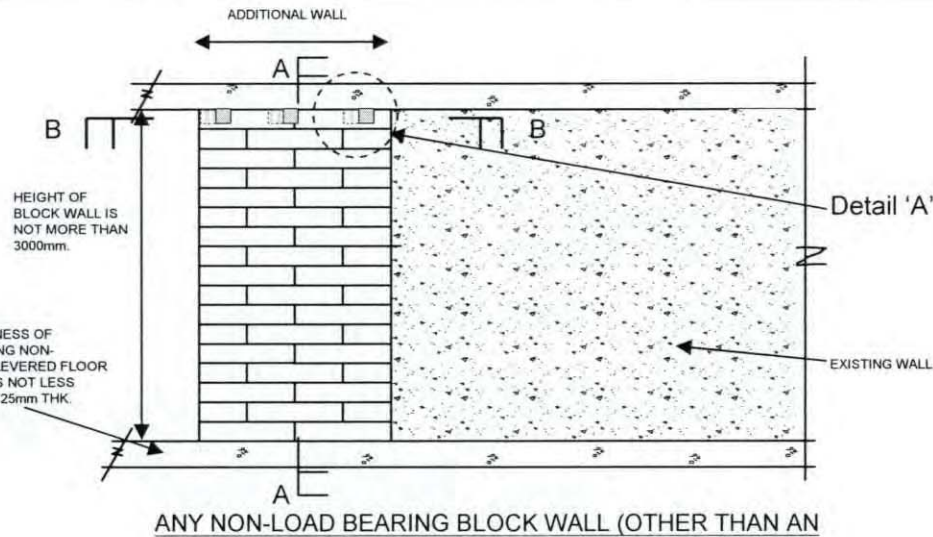

ANY NON-LOAD BEARING BLOCK WALL (OTHER THAN AN EXTERNAL BLOCK WALL)

Density of the screeding is not more than 650kg/m³. The screeding thickness may be more than 25mm but not more than 75mm, OR the screeding thickness may be more than 25mm but not more than 150mm where the aggregate area of the screeding is not more than 1.5m² within a floor area of 10m² of the flat and the nearest distance between each of the screeding area is not less than 2m.

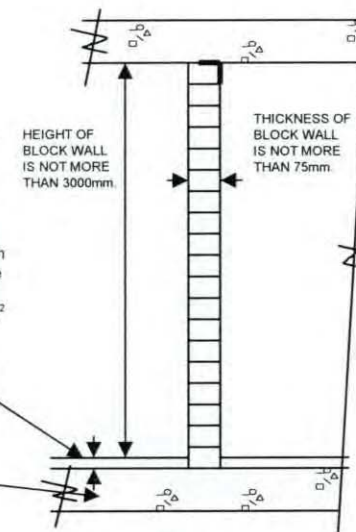

SECTION 'A-A'

GENERAL NOTES :

- The works carried out shall comply with the Buildings Ordinance and the provisions of other enactments. (Reference can be made to the examples listed in Sections 3 and 10 of the Guidelines.)
- All works shall comply with the following COP/ Standards:
 - Building (Construction) Regulations
 - BS 5628 – Code of Practice for the Use of Masonry : Part 1 Structural use of Unreinforced Masonry
 - Specifications and Method Statement for YTONG AAC Block Walls or their equivalent.
- Existing concrete grade is assumed to be Grade 30.
- Density of the screeding is not more than 650 kg/m³.
- All YTONG AAC blocks or their equivalent shall comply with BS6073-1 as solid block with the minimum compressive strength of 4 N/mm² and the density not more than 650 kg/m³.
- Mortar designation shall be Class (ii) to Table 1 of BS5628-1 with the mean compressive strength at 28 days of 4.5 N/mm² by site tests.

PREPARATION WORK:

- Obtain the relevant approved plans to ascertain the slab thickness and internal layout of the flat and that there are no unauthorized building works in the vicinity of the works.
- Carry out condition survey of the parent structure / existing condition prior to the commencement of works.
- Verify the existing screeding thickness by exposing the screeding at the location of any additional wall.

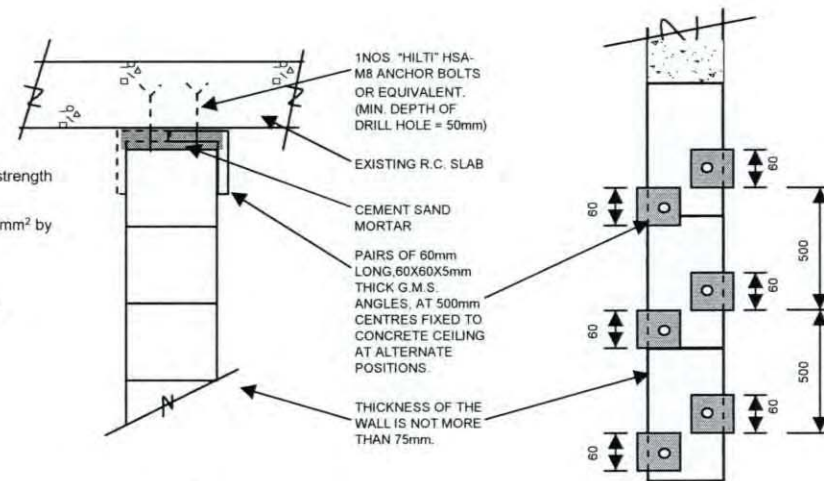

Detail 'A'

SECTION 'B-B'

MINOR WORKS ITEM 3.41

THICKENING OF ANY FLOOR SLAB OF A DOMESTIC FLAT BY LAYING SOLID SCREEDING

SHEET 1 OF 2

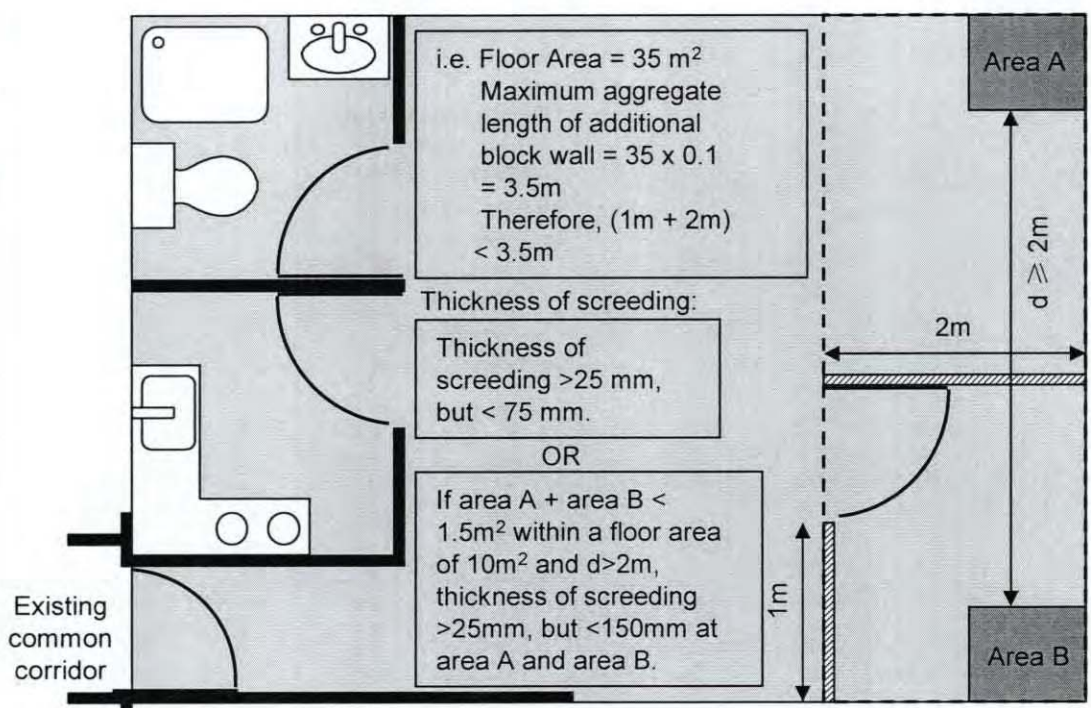

Floor area of the flat about 35 m² .(NOT TO SCALE)

LEGEND:

FLOOR AREA ABOUT 10m²

NON-LOAD BEARING WALL SHOWN ON APPROVED PLAN

NON-LOAD BEARING BLOCK WALL ACCORDING TO THE MINOR WORKS ITEM 3.39 IS CARRIED OUT

*The aggregate length of any additional block wall per m² of the floor area of the flat on which the wall is located is less than 0.1m.

Note:

1. Additional block wall of less than 0.1m per m² of the floor area of the flat and floor screeding not more than 25mm thick measured from the structural floor level are exempted works.
2. Aggregate length of any additional wall means the difference between the total length of the non-load bearing walls (excluding the width of any door openings on the walls) in a flat as shown on the approved plan and that as measured after the minor works item is carried out.
3. The wall finishes are not counted in the wall thickness.

MINOR WORKS ITEM 3.41	THICKENING OF ANY FLOOR SLAB OF A DOMESTIC FLAT BY LAYING SOLID SCREEDING	SHEET 2 OF 2
-----------------------	---	--------------

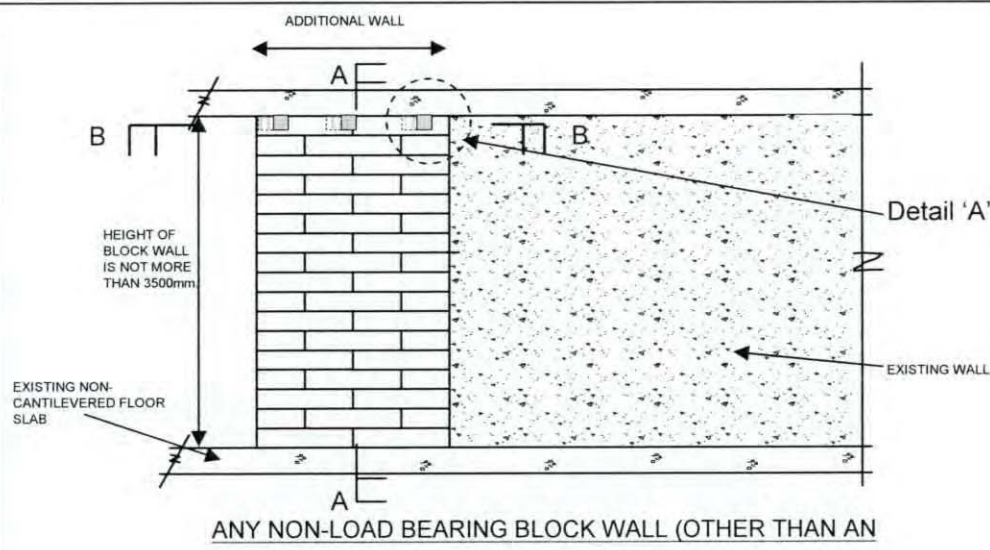

ANY NON-LOAD BEARING BLOCK WALL (OTHER THAN AN EXTERNAL BLOCK WALL)

Density of the screeding is not more than 650kg/m³. The screeding thickness may be more than 25mm but not more than 125mm, OR the screeding thickness may be more than 25mm but not more than 150mm where the aggregate area of the screeding is not more than 2.5m² within a floor area of 10m² of the flat and the nearest distance between each of the screeding area is not less than 2m.

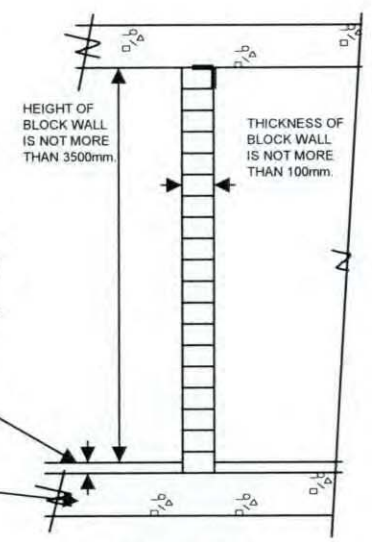

SECTION 'A-A'

GENERAL NOTES :

- The works carried out shall comply with the Buildings Ordinance and the provisions of other enactments. (Reference can be made to the examples listed in Sections 3 and 10 of the Guidelines.)
- All works shall comply with the following COP/ Standards:
 - Building (Construction) Regulations
 - BS 5628 – Code of Practice for the Use of Masonry : Part 1 Structural use of Unreinforced Masonry.
 - Specifications and Method Statement for YTONG AAC Block Walls or their equivalent.
- Existing concrete grade is assumed to be Grade 30.
- Density of the screeding is not more than 650 kg/m³.
- All YTONG AAC blocks or their equivalent shall comply with BS6073-1 as solid block with the minimum compressive strength of 4 N/mm² and the density not more than 650 kg/m³.
- Mortar designation shall be Class (ii) to Table 1 of BS5628-1 with the mean compressive strength at 28 days of 4.5 N/mm² by site tests.

PREPARATION WORK:

- Obtain the relevant approved plans to ascertain the slab thickness and internal layout of the flat and that there are no unauthorized building works in the vicinity of the works.
- Carry out condition survey of the parent structure / existing condition prior to the commencement of works.
- Verify the existing screeding thickness by exposing the screeding at the location of any additional wall.

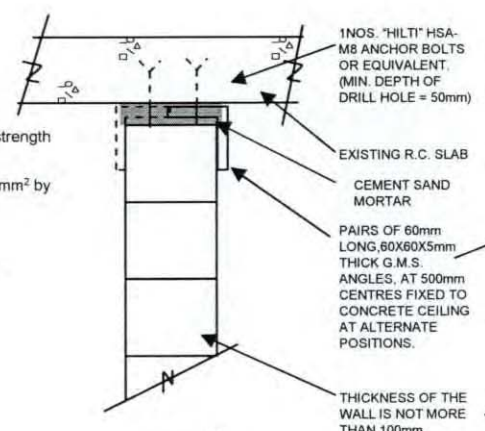

Detail 'A'

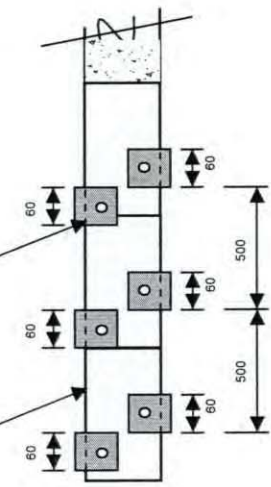

SECTION 'B-B'

MINOR WORKS ITEM 3.42

THICKENING OF ANY FLOOR SLAB OF A NON - DOMESTIC FLAT BY LAYING SOLID SCREEDING

SHEET 1 OF 2

