

CODE OF PRACTICE

FOR

THE PROVISION OF MEANS OF ESCAPE

IN CASE OF FIRE

1996

BUILDING AUTHORITY

HONG KONG

FOREWORD

Fire safety in a building is determined by a number of factors one of which is the provision of adequate means of escape in case of fire. Requirements for means of escape for buildings are laid down in section 41(1) of the Building (Planning) Regulations. This Code of Practice provides guidance on compliance with these requirements.

This Code will be reviewed regularly. Suggestions for improving it are welcome.

Building Authority

First issue : December 1959

This revision : June 1996

C O N T E N T S

Paragraph		Page
Part I - GENERAL PROVISIONS		
1.	Use of the Code	1
2.	Objectives	1
3.	Two Approaches to Fire Safety	1
4.	Interpretations	3
5.	Application	6
Part II - GENERAL PROVISIONS OF MEANS OF ESCAPE		
6.	Special Hazard Occupancy	7
7.	Assessment of Accommodation	7
8.	General Requirements of Exit Routes	9
9.	Buildings with a Single Staircase	11
10.	Exits from Rooms	12
11.	Exits from Storeys	13
12.	Exits at Ground Storey	15

13.	Access to Staircase(s) within a Building	15
14.	Direct Distance and Travel Distance	17
15.	Discharge Value and Width of Staircase	21
16.	Doors in Relation to Exits	25
17.	Construction of Staircases	27
18.	Ramps	28
19.	Lift Lobbies	28
20.	Basements	28
21.	Refuge Floors	29

**Part III - PROVISIONS OF MEANS OF ESCAPE IN PLACES OF
PUBLIC ENTERTAINMENT**

22.	Site	33
23.	Cinemas in Multi-storey Non-domestic or Composite Buildings	34
24.	Exit, Notices, etc.	35
25.	Entrance and Exit Routes	36
26.	Staircases	37
27.	Barriers	38
28.	Chains and Padlocks	38

29.	Gangways and Seatways	39
30.	Non-slippery Surfaces	39
31.	Edges of Steps	39
32.	Exit from Stages	39
33.	Lighting	40
34.	Temporary Buildings	40
COMMENTARIES		42
DIAGRAMS 1-7		

Part I - GENERAL PROVISIONS

1. Use of the Code

- 1.1 Authorised persons, registered structural engineers and any person responsible for the design of buildings may find this Code useful in establishing the requirements of the Building Authority for adequate means of escape in case of fire.
- 1.2 This Code gives guidance on how the Building Authority's requirements may be complied with.

2. Objectives

- 2.1 The objective of this Code is to announce provisions for the protection of buildings from the effects of fire by providing adequate means of escape in the event of fire and other emergencies.
- 2.2 There are other fire safety objectives : preventing the outbreak of fire, inhibiting the spread of fire, abating fire hazards, fire suppression, preventing loss of property and assisting in firefighting and rescue. Provisions for some of these can be found in the Buildings Ordinance and other Codes of Practice issued by the Building Authority.

3. Two Approaches to Fire Safety

- 3.1 Prescriptive Provisions : Compliance with the prescriptive provisions in this Code may be regarded as a reliable way to satisfy the Building Authority's requirements. Departure from these provisions will necessitate an alternative approach to be adopted and proved, in individual cases, to the satisfaction of the Building Authority as to compliance with requirements.

3.2 Alternative Approach : The Building Authority recognizes that fire safety may be approached in a number of ways the best of which is not necessarily prescriptive. This is particularly pertinent to buildings of special hazards which, because of their size, height, use, design, construction or location, may necessitate special consideration and specific standards. In this Code, the points to note for an alternative approach are set out.

3.3 For the assessment of the need of a building for fire protection, the Building Authority accepts the following as relevant factors :

- the anticipated risk of a fire occurring in a building;
- the anticipated severity of a fire;
- the ability of the structure of a building to resist the effect of fire and to minimize the spread of fire and smoke; and
- the consequential and possible danger to the people in and around a building.

3.4 Where an alternative approach is adopted, the Building Authority will assess its acceptability by reference to a set of criteria. This includes the means of escape, the means of access, the fire service installations, the fire resisting construction, the size, the height, the use, the location and the management of a building. An acceptable alternative approach should take into consideration these criteria and at the same time, should apply scientific and engineering principles to the protection of people and property from fire. Such an approach, which is also called "a fire engineering approach", may be the only viable means to a satisfactory standard of fire safety in some large and complex buildings.

3.5 A variety of measures may be taken to achieve fire safety in a building. These measures may provide for or enhance the following :

- the means to prevent fire;
- early fire warning by an automatic detection and warning system;
- the standard of the provision of means of escape;

- the facilities for smoke control;
- the control of the rate of spread of fire;
- the resistance of the effects of a fire;
- the capacity for fire containment;
- fire separation between buildings or parts of buildings;
- the standard of active measures for fire extinguishment or control;
- the facilities to assist in fire-fighting and rescue;
- the effectiveness of property management to minimize the outbreak of fire;
- the availability of personnel trained in fire protection; and
- the availability of any arrangement that could ensure the continued maintenance of fire protection systems.

3.6 Quantitative techniques may be used to evaluate risks and hazards. Some factors listed above may be given numerical values in certain circumstances. When quantitative methods are used, any assumptions made should be substantiated, where possible, by documents from competent authorities.

4. Interpretations

"balcony approach" means a balcony which is used as an external approach to a common staircase and which serves two or more occupancies.

"basement" means any storey of a building which is below the lower or lowest ground storey and from which any required exit route is in an upward direction.

"**capacity**" in relation to a room or storey of a building means that number of persons which the room or storey of a building is, for the purpose of this Code of Practice, to be taken as capable of holding. Provided that where there is on any storey the entrance to a maisonette, that storey shall, for the purpose of this definition, be deemed to include all floors of the maisonette.

"**direct distance**" means the distance measured in straight lines along the notional path from any part of a room to the centre of an exit door of the room.

"**discharge value**" means the number of persons that a staircase of a given width may be assumed to be capable of discharging from a given number of storeys.

"**exit door**" means a door from a storey, flat, or room, which gives access from such storey, flat or room on to an exit route.

"**exit route**" means a route by which persons in any storey of a building may reach a place of safety outside the building and may include rooms, door-ways, corridors, staircases, areas for refuge in refuge floors or other means of passage not being a revolving door, lift or escalator.

"**factory**" is as defined in the Factories and Industrial Undertakings Ordinance.

"**flat**" means a separate and self-contained dwelling, forming part of a building from some other part of which it is divided horizontally, and includes a maisonette and tenement floor.

"**ground storey**" means the storey in which is situated an entrance from a street to the building and, where a building fronts or abuts on more than one street and due to a difference in street levels there are two or more entrances serving different streets and situated in different storeys, means each such storey.

"**industrial undertaking**" is as defined in the Factories and Industrial Undertakings Ordinance.

"**maisonette**" means a flat not being a tenement floor and having more than one but not more than three storeys.

"**notifiable workplace**" is as defined in the Factories and Industrial Undertakings Ordinance.

"**place of public entertainment**" means any building or that part of a building constructed or adapted to be used for any public entertainment and includes the place itself and any means of ingress or egress for the purpose of and in connexion with such place, and in cases in which such place consists of a part or parts only of a building includes also any other part or parts of such building used or intended to be used for the purpose of and in connexion with such place. Public entertainment in this context is as defined in the Places of Public Entertainment Ordinance.

"**protected lobby**" means the intercepted approach, to a staircase or an exit route, which acts as a fire and smoke check between a storey and the staircase or the exit route, and enclosed throughout by walls and doors in accordance with the Code of Practice for Fire Resisting Construction.

"**refuge floor**" means a protected floor that serves as a refuge for the occupants of the building to assemble in case of fire.

"**travel distance**" means the horizontal distance measured on the floor along the centre line of the exit route between the centre of an exit door from a room and

- (a) the centre of the fire-resisting door to the enclosure of any one staircase;
- (b) if there is no such door, the first stair tread of the staircase; or
- (c) if the exit route leads directly to a street or to an open area at ground level complying with paragraph 8.2, any one of the points of discharge to the street or open area.

"usable floor area" means the aggregate of the areas of the floor or floors in a storey or a building excluding, unless otherwise specified, any staircases, public circulation space, lift landings, lavatories, water-closets, kitchens in self-contained flats, and any space occupied by machinery for any lift, air-conditioning system or similar service provided for the building.

5. Application

5.1 The provisions in this Code apply to all buildings with the exception of domestic buildings -

- (a) having not more than three main domestic storeys;
- (b) the level of the highest floor of which is not more than 13 m above the ground level; and
- (c) used or intended to be used for occupation by a single family.

5.2 Where any Ordinance or any Regulations made under any Ordinance includes any provision relating to means of escape in case of fire, nothing in this Code of Practice shall be deemed to overrule such provision. In this connexion attention is drawn to the following Ordinances and the Regulations made thereunder -

- (a) Bedspace Apartments Ordinance, Cap. 447;
- (b) Child Care Centres Ordinance, Cap. 243;
- (c) Education Ordinance, Cap. 279;
- (d) Factories and Industrial Undertakings Ordinance, Cap. 59;
- (e) Hotel and Guesthouse Accommodation Ordinance, Cap. 349;
- (f) Residential Care Homes (Elderly Persons) Ordinance, Cap. 459;

- 5.3 For situations not covered in this Code, the means of escape will be determined by the Building Authority according to the circumstances of individual cases.

PART II : GENERAL PROVISIONS OF MEANS OF ESCAPE

6. Special Hazard Occupancy

- 6.1 In a building where an area of special hazard occupancy is directly associated with an occupancy of normal hazard (for example store rooms for combustible material in a hotel; a kitchen attached to a restaurant; a boiler room in a hotel) any opening from such area of special hazard into any exit route should be provided with a protected lobby. The means of escape from an area of normal hazard should not pass through any area of special hazard.
- 6.2 For the purpose of this paragraph, the hazard of occupancy should be the relative danger of the start and spread of fire, the relative danger of smoke or gases generated and the relative danger of explosion or other occurrence which may endanger the lives and safety of the occupants.

[Note : (a) The requirements for fire resisting construction in areas of special hazard occupancy are contained in the Code of Practice for Fire Resisting Construction.

(b) A kitchen attached to a restaurant is an "industrial undertaking" as defined in the Factories and Industrial Undertakings Ordinance.]

7. Assessment of Accommodation

As a guide to assessing the requirements for means of escape, or the capacity or population of various portions of a building, or the number of persons and population density within a building, the following Table 1 and notes should be the basis of calculation.

Table 1

Intended use of storey	Factor representing usable floor area in m ² per person
(a) Assembly halls, auditoria and stadia without seating or with movable seating	0.5
(b) Areas accessible to the public in viewing galleries, banking halls, betting centres and places where public service counters are provided	0.5
(c) Dance halls (calculated on dancing area), disco and reception area for restaurant.	0.75
(d) Restaurants(calculated on dining area), dining area, lounges, committee rooms, conference rooms, meeting rooms, common rooms, function room and waiting rooms	1
(e) Kitchens attached to restaurants	4.5
(f) Museums, exhibition halls, trademarts and display areas	2
(g) Supermarkets, showrooms, jewellery and goldsmith shops, pawn shops and money changers.	2
(h) Shopping arcades, department stores and shopping areas - basement, G/F, 1/F & 2/F - 3/F & above	3 4.5
(i) Offices	9
(j) Tenement houses, barracks, dormitories, and self-contained flats comprising a single room or having the main living area subdivided by rooms	3
(k) Self-contained flats with corridor or balcony access having five or more flats on each floor served by each staircase	4.5
(l) Flats not covered by (j) or (k)	9
(m) Flatted factories	4.5
(n) Warehouses, godowns and storage areas	30
(o) Classrooms of school not covered by Education Ordinance and other lecture rooms, library, and study rooms	2

Notes :

- (i) For definition of "usable floor area" see paragraph 4. For uses in category (g) & (h), the usable floor areas shall include the public circulation space as it normally forms part of the premises, except for shopping arcades where a notional arcade width of 2.5m and 3.0m for single-loaded and double-loaded shopping malls respectively will be used.
- (ii) Hospitals, hotels, hostels, places of public entertainment etc. will be assessed by the Building Authority on the basis of detailed layout plans.
- (iii) The worst scenario will be adopted in order to calculate the maximum capacity of carpark but in no case less than 1.5 carparking spaces per person. The travel distance in carpark should be measured along the aisle based on the assumption that the carpark is full.
- (iv) Single user specialized industrial workplace will be determined by the Commissioner for Labour according to the specialized trade process proposed.
- (v) For any use not specified in this table, the Building Authority should determine the factor to be used.
- (vi) The Building Authority recognizes actual counting as a reliable way to establish the population of a building.

8. General Requirements of Exit Routes

- 8.1 Every building to which this Code applies should be so constructed that there are available from each storey of the building such exits and exit routes as will comply with the requirements set out in this Code.
- 8.2 Every exit route should lead directly to a street or to an open area at ground level having unobstructed access, not less in width than the total required width of exit routes discharging into such an area, to a street. Such access to a street should not be closed with doors or gates unless such doors or gates are capable of being readily opened from inside without the use of key(s) and in the direction of exit.
- 8.3 If an exit staircase leads to an open area at any upper floor levels of the building such as the podium level, instead of leading directly to a street or to an open area complying with paragraph 8.2, the staircase should lead to an exit route at such floor level which -
- (a) should be adequately defined by permanent features eg : handrail, railing;
 - (b) should lead to a place of ultimate safety, i.e. a street or an open area complying with paragraph 8.2; and
 - (c) should be designed and constructed as if it is part of the exit staircase complying with the requirements in this Code and those in the Code of Practice for Fire Resisting Construction.

For the purpose of complying with the requirements in the Code of Practice of Fire Resisting Construction, the roof of the exit route should be regarded as an external wall and the slab of the open area should be regarded as a floor.

- 8.4 Every part of an exit route should be provided with artificial lighting providing a horizontal illuminance at floor level of not less than 30 lux and backed up by an emergency lighting system providing a horizontal illuminance at floor level of not less than 2 lux. The design of the emergency lighting system should comply with the Code of Practice for Minimum Fire Service Installations and Equipment.
- 8.5 Exit routes from a building should not discharge into a private lane unless the lane is properly paved and free from any permanent obstruction and the Building Authority is satisfied with the integrity of the lane as a means of escape.

- 8.6 If the final point of discharge of the exit routes at ground level are so sited that they adjoin each other or any other accommodation, the walls enclosing such exit routes should be returned along the frontage of the final discharge or project from the frontage for a distance of not less than 450 mm, provided that any return should not reduce the effective width of the exit route.
- 8.7 Every part of an exit route should have a clear height of not less than 2000 mm, provided that sprinkler heads may be installed along the side wall of the exit route and every such sprinkler head should not project :
- (a) more than 90 mm from such side wall; and
 - (b) so as to reduce the clear height of the exit route by more than 105 mm.
- 8.8 At the final point of discharge of an exit route at ground level where there is a drop in level, any door or gate, if installed, should be set back from the line of drop in level for a distance of not less than the width of the exit route. If the drop in level consists of a single step, it should be so marked that the step is clearly visible.

9. Buildings with a Single Staircase

- 9.1 Single staircases may be permitted in buildings not exceeding 6 storeys in height and the level of the floor of the uppermost storey is not more than 17 m above the level of the ground at the point of discharge of the staircase.
- 9.2 No building will be permitted to have a single staircase unless such building complies with the following conditions :-
- (a) no room or storey of the building may be used for any occupancy other than domestic or offices, except that the ground storey may be used for the purposes of a shop or carparking space provided that the requirements for staircase enclosures in the Code of Practice for Fire Resisting Construction are complied with;
 - (b) adequate access should be provided at ground level to enable a rescue ladder/appliance to reach at least one window of every separate occupancy on each floor above the ground storey. Such access shall be at least:-
 - (i) 3m wide in the case of a building in which the level of the highest floor is not more than 10 m above ground level; and
 - (ii) 4.5m wide in the case of a building in which the level of the highest floor is more than 10 m above ground level.
 - (c) in the case of a building in which the level of the highest floor is not more than 13m above ground level the usable floor area of any storey above the ground floor should not exceed 250 m²;
 - (d) in the case of a building in which the level of the highest floor is more than 13 m above ground level the usable floor area of any storey above the ground floor should not exceed 150 m²; and

- (e) in the case of a building in which the level of the highest floor is more than 13 m above ground level:-
- (i) access to the staircase at each storey should be through a protected lobby. Such lobby should be designed as a common area and an integral part of the staircase so that it could not be readily incorporated as part of any adjacent unit(s) of accommodation;
 - (ii) the staircase should be continued to the roof;
 - (iii) there should be available on the roof an area of flat surface for refuge of not less than 0.5 m² per person based on the total population of the building above ground storey determined according to Table 1. Such flat roof should be accessible directly from the staircase, clear of any obstruction, and is so positioned that it is readily accessible for rescue purposes; and
 - (iv) the roof should comply with the requirements in the Code of Practice for Fire Resisting Construction.

10. Exits from Rooms

- 10.1 There should be available from every room of a capacity exceeding 3 persons not less than the number of exit doors shown in Table 2 according to the capacity of the room. The width of each exit door and the total width of all the exit doors shall be not less than the width shown in Table 2 according to the capacity and the number of exit doors provided.
- 10.2 Every exit door so provided should give access to an exit route which complies with paragraph 8 and which is independent of any other exit route to which access may be directly obtained from that room. Provided that where the capacity does not exceed 200 persons the exit doors may give access to a single corridor or balcony approach from which it is possible to escape in more than one direction.
- 10.3 Where two or more exit doors (required by Table 2) vary in width, any width of an exit door in such group in excess of 50% above the width of the narrowest exit door in such group should not be included in the calculation for the minimum total width of exit doors as required in column 3 of Table 2.

11. Exits from Storeys

11.1 Every building, except those buildings permitted under paragraph 6 to have a single staircase, should be so constructed that there are available from each storey not less than 2 exit routes or such greater number as may be required by Table 2. The width of each exit route and the total width of all the exit routes should be not less than the width shown in Table 2 according to the capacity and the number of exit route provided. Provided that :-

- (a) this requirement should apply to only one of the storeys of a maisonette,
- (b) where two or more exit routes (required by Table 2 to serve a storey) vary in width, any width of an exit route in such group in excess of 50% above the width of the narrowest exit route in such group should not be included in the calculation for the minimum total width of exit routes as required by column 4 of Table 2.

11.2 Where two or more exit staircases are required, people using one staircase should be able to gain access to at least one of the other staircases at any time without having to pass through other person's private premises. Such access should be provided either at each floor or, where refuge floors are provided, at the refuge floor(s) and the roof. The requirements in this paragraph do not apply to a domestic building or a composite building not exceeding 15 storeys in height above the lowest ground storey.

Table 2

Table showing minimum number of exit doors from a room, or exit routes from a storey, and required minimum width thereof

Capacity of room or storey	Min. No. of exit doors (from room) or exit routes (from storey)	Min. Total Width of		Min. Width of each	
		exit doors	exit routes	exit door	exit route
4 - 30	1			750 mm	1050 mm
31 - 200	2	1750 mm	2100 mm	850 mm	1050 mm
201 - 300	2	2500 mm	2500 mm	1050 mm	1050 mm
301 - 500	2	3000 mm	3000 mm	1050 mm	1050 mm
501 - 750	3	4500 mm	4500 mm	1200 mm	1200 mm
751 - 1000	4	6000 mm	6000 mm	1200 mm	1200 mm
1001 - 1250	5	7500 mm	7500 mm	1350 mm	1350 mm
1251 - 1500	6	9000 mm	9000 mm	1350 mm	1350 mm
over 1500	7 or such greater number as the Building Authority may require	to be calculated at the rate of 300mm per 50 persons		1500 mm	1500 mm

Notes :

- (i) In the case of Places of Public Entertainment attention is drawn to Part III of this Code, the requirements of which must be followed.
- (ii) The width of an exit door should be the least clear width measured between the vertical members of the door frame.
- (iii) The width of a staircase, stair landing, passage or corridor comprising an exit route should be measured between the finished surfaces of the walls or of the inner sides of any balustrade and should not be decreased by the introduction of any projections other than handrails the projection of which should not exceed 90 mm.
- (iv) The Table shows the minimum requirement on the assumption that doors can be readily and freely opened by occupants in case of fire i.e. no lock.
- (v) In case of shopping arcades, department stores and shopping areas at basement, G/F, 1/F & 2/F over 500 persons, minimum no. of exit doors (from room) or exit routes (from storey) may be lesser than that as shown on Table 2 subject to the compliance of minimum total width of exit doors/routes as shown on Table 2.

12. Exits at Ground Storey

- 12.1 The enclosing walls of every staircase should be so continued at ground storey as to separate from the remainder of the building any passage or corridor leading from the staircase to any ground storey exit door to which the staircase gives access; provided that -
- (a) in the case of a building served by two or more staircases, a cloakroom, lavatory, water-closet, caretaker's office, fire control room or caretaker's counter may open off such passage-way; and
 - (b) in the case of a building served by three or more staircases one in every three such staircases may discharge through fire resisting doors to a hall or shopping arcade and that part of the hall or shopping arcade which forms the actual exit route should comply with the requirements of paragraphs 8.2 and 8.4.
- 12.2 Where an exit route from a ground storey forms also the exit route from a staircase, the width of such exit route should be not less than the sum of -
- (a) half the width required for the exit from the ground storey; and
 - (b) the width required for the staircase from the upper storeys; and
 - (c) the width required for the staircase, if any, from the basements.

13. Access to Staircase(s) within a Building

- 13.1 Every staircase should be separated from the remainder of the building in accordance with the requirements of the Code of Practice for Fire Resisting Construction.

(see **diagram 1**)

- 13.2 In the case of a building with a single staircase attention is drawn to the requirements in paragraph 9.

- 13.3 In the case of a building with two or more staircases, the access to the staircases should be so arranged that:-
- (a) each staircase is approached from a different direction provided that deadends will be permitted in accordance with paragraph 14.3(b);
 - (b) the door of one staircase, or the nearest point in the perimeter of the landing to the staircase where there is no door, should not be nearer than 6m from the door or a similar point of any other staircase measured in a straight line along the wall.
- 13.4 The means of escape from any part of a building should be so arranged that it is not necessary to pass through one staircase enclosure or the landing of one staircase, as the case may be, in order to reach an alternative staircase.
- 13.5 Where internal access is provided,
- (a) no door opening on to an internal common corridor should at any part of its swing reduce the minimum required width of such corridor;
 - (b) a protected lobby should be provided to each and every staircase unless the staircase is :
 - (i) a staircase of which at least 50 % of its perimeter, measured on plan, is open, from the top of the balustrade or parapet to the underside of the flight of the staircase immediately above, to the external air; or
 - (ii) a staircase in a single staircase building in which the level of the highest floor is not more than 13 m above ground level.
 - (iii) a staircase in a building which is provided with two or more stairs and the level of the highest floor is not more than 20 m above ground level.

Such lobby shall be designed as a common area and an integral part of the staircase so that it could not be readily incorporated as part of any adjacent unit(s) of accommodation.

13.6 Where balcony approach is provided,

- (a) a balcony approach should be protected in accordance with the requirements of the Code of Practice for Fire Resisting Construction;
- (b) the landing of any staircase should not form part of the balcony approach;
- (c) no door opening on to the balcony approach should at any part of its swing reduce the minimum required width of the balcony approach; and
- (d) every window opening on to the balcony approach should be so arranged that it should not be possible to fix any such window in an open position in such a manner as will reduce the minimum required width of the balcony. The sill of such window should be not less than 1000 mm above the balcony level. Provided that nothing in this paragraph should prevent a window from opening through 180 degrees and being fixed open in such position, or the use of fanlights at a height of not less than 2000 mm above the balcony level.

14. Direct Distance and Travel Distance

- 14.1 The direct distance within a room which is provided with an alternative exit door leading to an alternative staircase or an alternative point of discharge to a street or to an open area at ground level complying with paragraph 8.2, as the case may be, should not exceed 18m except in exhibition hall, concert hall, transport terminal and similar buildings. Where such alternative exit door is not provided, the direct distance should not exceed 15m.

(see diagrams 2, 3 and 4)

- 14.2 In a storey of a single-staircase building, the travel distance and the sum of the direct distance and travel distance should not exceed the limitations stipulated in Table 3.

Table 3 Limitation on Direct Distance and Travel Distance for Single-staircase Buildings

Type of exit route*	Maximum travel distance	Maximum sum of the direct distance and travel distance
(A)	18 m	24 m
(B)	12 m	24 m
(C)	18 m	18 m

*Notes : (A) exit route along balcony approach or internal corridor with ventilation and complying with the requirements of the Code of Practice for Fire Resisting Construction.

(B) exit route along internal corridor without ventilation and complying with the requirements of the Code of Practice for Fire Resisting Construction.

(C) storey partitioned into rooms but exit route is not along balcony approach or internal corridor which complies with the requirements of the Code of Practice for Fire Resisting Construction.

14.3 In a storey which is served by two or more staircases or points of discharge to a street or to an open area at ground level complying with paragraph 8.2, as the case may be, -

(a) the travel distance and the sum of the direct distance and travel distance should not exceed the limitations stipulated in Table 4.

Table 4 Limitation on Direct Distance and Travel Distance for Buildings with Two or More Staircases

Use of the premises or part of the premises	Type of exit route*	Maximum travel distance	Maximum sum of the direct distance and travel distance
(i) offices, schools and shops	(A)	36 m	45 m
	(B)	24 m	36 m
	(C)	30 m	30 m
(ii) all other cases	(A)	30 m	36 m
	(B)	24 m	36 m
	(C)	30 m	30 m

*Notes : (A) exit route along balcony approach or internal corridor with ventilation and complying with the requirements of the Code of Practice for Fire Resisting Construction.

(B) exit route along internal corridor without ventilation and complying with the requirements of the Code of Practice for Fire Resisting Construction.

(C) storey partitioned into rooms but exit route is not along balcony approach or internal corridor which complies with the requirements of the Code of Practice for Fire Resisting Construction.

(b) where the direction of travel from an exit door of a room to a staircase or a point of discharge to a street or to an open area at ground level complying with paragraph 8.2, as the case may be, is possible in one direction only (i.e. deadend), the sum of the direct distance and travel distance should not exceed 18m.

(c) the horizontal distance along the corridor measured on the floor along the centre line of the exit route between a staircase or a point of discharge and any one of the other staircases or points of discharge, as the case may be, should not exceed 48m. In the case of staircases, the distance should be measured between -

(i) the centre of the fire resisting doors to the enclosures of the staircases;

(ii) if there is no such door, the landings of the staircases; or

(iii) in the case of an open podium floor, the points as described in (i) or (ii) above, or the first staircase treads nearest to the podium.

14.4 If the storey is not partitioned into rooms or the internal layout of partitions, fittings, etc. is not known when plans are submitted (i.e. open plan layout), the direct distance should not exceed 30m for all cases where a secondary exit door is provided and should not exceed 18m if a secondary exit door is not provided.

(see diagram 5)

14.5 An inner room, i.e. a room from which the only exit route is through another room, should not be acceptable unless the following conditions are satisfied : -

(a) the capacity of the inner room does not exceed 30;

(b) the exit route from the inner room does not pass through more than one other room;

(c) the escape distance from any point in the inner room to the exit of the room giving access to the inner room does not exceed the direct distance stipulated in paragraph 14.1 above;

(d) the room giving access to the inner room is not an area of special hazard and is under the control of the same occupant; and

(e) a vision panel, except in the case of a toilet, is located in the door or walls of the inner room.

- 14.6 In any room where two or more exit doors are required to be provided under Table 2, the line of the direct distance from any point in the room to one of the exit doors should form an angle of not less than 30° with the line of the direct distance from the same point to any of the other exit doors.
- 14.7 For the purposes of paragraphs 14.1 and 14.4, a secondary exit door is not considered to be provided unless the line of the direct distance from any point in the room to one of the exit doors forms an angle of not less than 30° with the line of the direct distance from the same point to the other exit door.
- 14.8 For the purposes of paragraphs 14.2 and 14.3, an internal corridor with ventilation should be one which is -
- (a) cross ventilated by permanent openings which may be fitted with ventilator(s) provided that such ventilator(s) should be triggered to open by automatic smoke detector located in the space to be ventilated and fitted with a manual override. The openings should have a total free area of at least 6.25% of the floor area of the corridor to be ventilated and each opening should have a free area of at least 1.5 m²; or
 - (b) provided with a static or a dynamic smoke extraction system to the satisfaction of the Director of Fire Services.

15. Discharge Value and Width of Staircase

- 15.1 The staircases serving the storeys of a building above the ground storey should have a total discharge value of not less than the total capacity of those storeys assessed in accordance with paragraph 7.
- 15.2 The staircases serving the basements of a building should have a total discharge value of not less than the total capacity of those basements assessed in accordance with paragraph 7.
- 15.3 The discharge value of a staircase in a non-sprinklered building should be assessed from Table 5 according to the width of the staircase and the number of storeys it serves.

Table 5 : Discharge Value of a Staircase in a Non-sprinklered Building

No. of Storey served	Width of Staircase						
	1050mm but under 1200mm	1200mm but under 1350mm	1350mm but under 1500mm	1500mm but under 1600mm	1600mm but under 1700mm	1700mm but under 1800mm	1800mm but under 1900mm
1	210	240	270	300	320	340	360
2	242	278	315	351	377	402	428
3	274	316	360	402	434	464	496
4	306	354	405	453	491	526	564
5	338	392	450	504	548	588	632
6	370	430	495	555	605	650	700
7	402	468	540	606	662	712	768
8	434	506	585	657	719	774	836
9	466	544	630	708	776	836	904
10	498	582	675	759	833	898	972
Each additional storey add	32	38	45	51	57	62	68

Note : The discharge value of a staircase having a width more than 1900 mm may be obtained by using linear projection from the table.

15.4 The discharge value of a staircase in a sprinklered building should be assessed from Table 6 according to the width of the staircase and the number of storeys it serves.

Table 6 : Discharge Value of a Staircase in a Sprinklered Building

No. of Storey served	Width of Staircase						
	1050mm but under 1200mm	1200mm but under 1350mm	1350mm but under 1500mm	1500mm but under 1600mm	1600mm but under 1700mm	1700mm but under 1800mm	1800mm but under 1900mm
1	420	480	540	600	640	680	720
2	452	518	585	651	697	742	788
3	484	556	630	702	754	804	856
4	516	594	675	753	811	866	924
5	548	632	720	804	868	928	992
6	580	670	765	855	925	990	1060
7	612	708	810	906	982	1052	1128
8	644	746	855	957	1039	1114	1196
9	676	784	900	1008	1096	1176	1264
10	708	822	945	1059	1153	1238	1332
Each additional storey add	32	38	45	51	57	62	68

Note : The discharge value of a staircase having a width more than 1900 mm may be obtained by using linear projection from the table.

- 15.5 The discharge value of a staircase where the direction of exit is upwards should be that assessed from Table 5 for non-sprinklered building or Table 6 for sprinklered building as the case may be, and multiplied by a reduction factor of **0.8**.
- 15.6 The discharge value of a scissors staircase without any intermediate landing between 2 consecutive floors should be that assessed from Table 5 for non-sprinklered building or Table 6 for sprinklered building as the case may be, and multiplied by a reduction factor of **0.7**.
- 15.7 For the purpose of this paragraph, sprinklered buildings are those where the whole building is protected by sprinklers. Where part of a building is protected by sprinklers and other part is not and the staircases serving these different parts are not separated, the discharge value of such staircases should be assessed from Table 5.
- 15.8 The total width of staircases serving a building having a total capacity of not less than 10,000 persons for sport arenas, stadia, convention centres, passenger terminals or similar uses should be 1.2 times the total width of exit routes required by Table 2 according to the capacity of the area concerned. Where part of the exits lead directly to a place of ultimate safety which means a street or the open area referred to in paragraph 8.2 and part of the exits lead to staircases, the total width of the staircases should be 1.2 times the width of the exit routes calculated by deducting the total width of exits leading directly to the place of ultimate safety from the total width of exit routes required by Table 2 according to the capacity of the area concerned.
- 15.9 A building having a total capacity of not less than 10,000 persons may necessitate special consideration. Fire engineering approach may be the only viable means to a satisfactory standard of a fire safety.

16. Doors in Relation to Exits

- 16.1 Every door across an exit, or into an exit route from a room or storey the capacity of which exceeds 30, should -
- (a) open in the direction of exit;
 - (b) if constructed to open both ways, have a transparent upper view panel.
- 16.2 If it is necessary to secure an exit door against entry from outside, the locking device shall be of the type which is capable of being readily opened from the inside without the use of a key. A locking device which is electrically operated is acceptable provided that such lock is capable of automatic release upon actuation of a smoke detection system or the operation of an alarm system or a central manual override, installed to the satisfaction of the Director of Fire Services. Upon power failure, the electrical locking device shall also be released automatically. In the case of a door to a staircase or a protected lobby of the staircase, the security mechanism should not affect compliance with the requirements in paragraph 11.2.
- 16.3 Every door opening on to a landing between flights of a staircase should not at any point of its swing, reduce the effective radius of the landing to less than the width of the staircase.
- 16.4 Exit door from a room or storey having a capacity in excess of 3 persons should not be less than 750mm in width. In the case of a double leaf door, no leaf of such door should be less in width than 600 mm and, where the meeting stiles are rebated, a checking device to control the closing order of the doors should be installed. Such checking device should ensure that both leaves of door are closed in the correct order and position.
- 16.5 Every door giving access to a protected lobby from a staircase enclosure or from a storey should be provided with a transparent upper view panel of the requisite fire resistance.

- 16.6 In the case of factories and industrial undertakings that are required to be notified to the Commissioner for Labour, i.e. notifiable workplaces,
- (a) every exit door leading out of a notifiable workplace, and the doors of every room in a notifiable workplace in which 10 persons or more are employed, should be constructed so as to open outwards;
 - (b) every exit door leading out of a notifiable workplace should be fitted with an effective self-closing device.
- 16.7 Every door to a staircase or a protected lobby of the staircase should comply with the following requirements:
- (a) the self-closing mechanism should not be capable of allowing a check action to hold the door open and
 - (b) appropriate notices should be fixed to both sides of the doors to remind building users that the doors should normally be kept closed.
- 16.8 Every door across an exit or into an exit route from a room, except a door to a staircase or a protected lobby of the staircase, if required to be self-closing, may be held open in normal times provided that the hold-open device can be released to allow the door to become self-closing again manually and automatically upon actuation of a smoke detection system or the operation of an alarm system designed, installed to the satisfaction of the Director of Fire Services.

17. Construction of Staircases

- 17.1 Every staircase to which this Code applies should be constructed in accordance with the requirements of the Code of Practice for Fire Resisting Construction.
- 17.2 Staircases should be arranged in straight flights without winders, each flight should consist of not more than 16 risers nor less than 2 risers. Treads should be not less than 225 mm wide, measured clear of nosings and the risers should be not more than 175 mm high. Provided that :-
- (a) in schools treads should be not less than 250 mm wide and the risers should be not more than 150 mm nor less than 75 mm high, and
 - (b) in places of public entertainment treads should be not less than 280 mm wide and not more than 150 mm high.
- 17.3 Landings should be provided at the top and bottom of each flight not less in width and length than the staircase width, and no exit door should at any part of its swing reduce the effective width or effective radius of such landing as the case may be.
- 17.4 Every staircase should have a clear width of not less than that required by paragraph 11.1 and a clear height of not less than 2000 mm.
- 17.5 No staircase should exceed 1800 mm in width unless it is divided by a central handrail into separate sections, each of which should be not less than 1050 mm in width.
- 17.6 There should be provided a handrail on each side of the staircase. Every such handrail should -
- (a) be at a height not less than 850 mm nor more than 1100 mm;
 - (b) not project so as to reduce the clear width of the stair by more than 90 mm, for each handrail; and
 - (c) be continuous throughout each flight, but need not be carried round a landing or half landing except in the case of a place of public entertainment.

18. Ramps

The gradient of every ramp forming part of an exit route should not at any part be steeper than 1:12.

19. Lift Lobbies

Every lift lobby should have access, without any obstruction and lockable door, to an exit route. Such access should be available at all times to any person who may come out from a lift car to the lift lobby. The provision of a direct intercom link connecting a lift lobby with the management office of the building will be accepted as an adequate alternative if the building is provided with good management.

20. Basements

20.1 Every basement should have not less than 2 exits excepting a basement -

(a) the floor of which is not more than 3000 mm below the level of the ground to which the exit serving such basement gives access;

(b) the area of which does not exceed 150 m²; and

(c) which is used solely for a lavatory or plantroom.

20.2 No staircase serving the storeys of a building above the ground storey should be continued direct to a basement.

20.3 Sufficient directional and exit signs, in English and Chinese, to indicate the direction of exit should be displayed in each staircase serving the basement(s). Such signs should be illuminated by a light on two systems as the lighting referred to in paragraph 8.4 and be -

(a) in rectangular shape and should be in either one of the following forms :

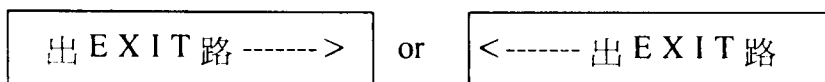

All words and characters should be in block letters not less than 50 mm high. The wording should be in white and the background in green or the wording in green with the background in white or black.

- (b) not easily defaced or damaged; and
- (c) displayed on the central part of the side wall of each flight of the staircase(s) at a height of 1500 mm from and parallel to the nosing line of the flight.

20.4 In the case of a basement, except a basement used solely as a lavatory, which is below the lowest ground storey and from which all the required exit routes discharge in an upward direction, at least one exit from such basement should discharge independently of any other exit into a street or area having access to a street in accordance with the requirements of paragraph 8.2.

21. Refuge Floors

21.1 Subject to paragraph 21.5, refuge floors should be provided in all buildings exceeding 25 storeys in height above the lowest ground storey, at not more than 20 storeys and 25 storeys respectively for industrial and non-industrial buildings from any other refuge floor, or above the street or the open area referred to in paragraph 8.2. For the purpose of this paragraph the number of storeys may exclude storeys which contain solely mechanical plants.

21.2 Every refuge floor, except that provided under paragraphs 21.3 and 21.5, should comply with the following requirements :

- (a) there is no occupied accommodation or accessible mechanical plant room, except fire services water tanks and associated fire service installation plant room, at the same level as the refuge floor;
- (b) the net area for refuge should be not less than 50 % of the total gross floor area of the refuge floor and should have a clear height of not less than 2300 mm;

- (c) the minimum dimension of the area for refuge should be at least 50% greater than the width of the widest staircase passing through the refuge floor;
- (d) the area for refuge should be separated from the remainder of the building in accordance with the requirements in the Code of Practice for Fire Resisting Construction;
- (e) the area for refuge should be open-sided above safe parapet height on at least two opposite sides to provide adequate cross ventilation; the open sides should comply with the requirements in the Code of Practice for Fire Resisting Construction;
- (f) any staircase passing through a refuge floor should be discontinued at such level so that the exit route is diverted to pass over part of the refuge area before it is continued to exit downwards;
- (g) every part of the area for refuge should be provided with artificial lighting providing a horizontal illuminance at floor level of not less than 30 lux and backed up by an emergency lighting system providing a horizontal illuminance at floor level of not less than 2 lux. The design of the emergency lighting system should comply with the Code of Practice for Minimum Fire Service Installations and Equipment;
- (h) a refuge floor should be provided with such fire services installation and equipment as may be required by the Director of Fire Services; and
- (i) a refuge floor should be served by a fireman's lift. The lift doors should not open onto the refuge floor in normal operation and should be locked at all times until automatically released on actuation of the fireman's switch.

(see diagram 6)

- 21.3 The main roof of a building may be regarded as a refuge floor for the purpose of paragraphs 21.1 and 21.5 provided that -
- (a) it should be of flat surface and should comply with the requirements in the Code of Practice for Fire Resisting Construction;
 - (b) the net area for refuge should be not less than 50% of the gross floor area of a typical floor below the main roof;
 - (c) any staircase serving the floors immediately below the main roof should be continued to give access to the main roof without any obstruction at all times;
 - (d) the minimum dimension of the area for refuge should be at least 50% greater than the width of the widest staircase serving the roof; and
 - (e) every part of the area for refuge should be provided with artificial lighting providing a horizontal illuminance at floor level of not less than 30 lux and backed up by an emergency lighting system providing a horizontal illuminance at floor level of not less than 2 lux. The design of the emergency lighting system should comply with the Code of Practice for Minimum Fire Service Installations and Equipment.

(see diagram 7)

- 21.4 At each refuge floor, notices and signs should be provided in the following manners :
- (a) a sign indicating the staircase number and a sign indicating the entrance to the refuge floor should be displayed inside each staircase at a position immediately before entering the refuge floor at a height of 1500mm above the landing or the step immediately below the staircase number;
 - (b) a notice in rectangular shape and in the following form should be displayed at a position immediately after entering the refuge floor from each staircase at a height of 1500mm above the floor level;

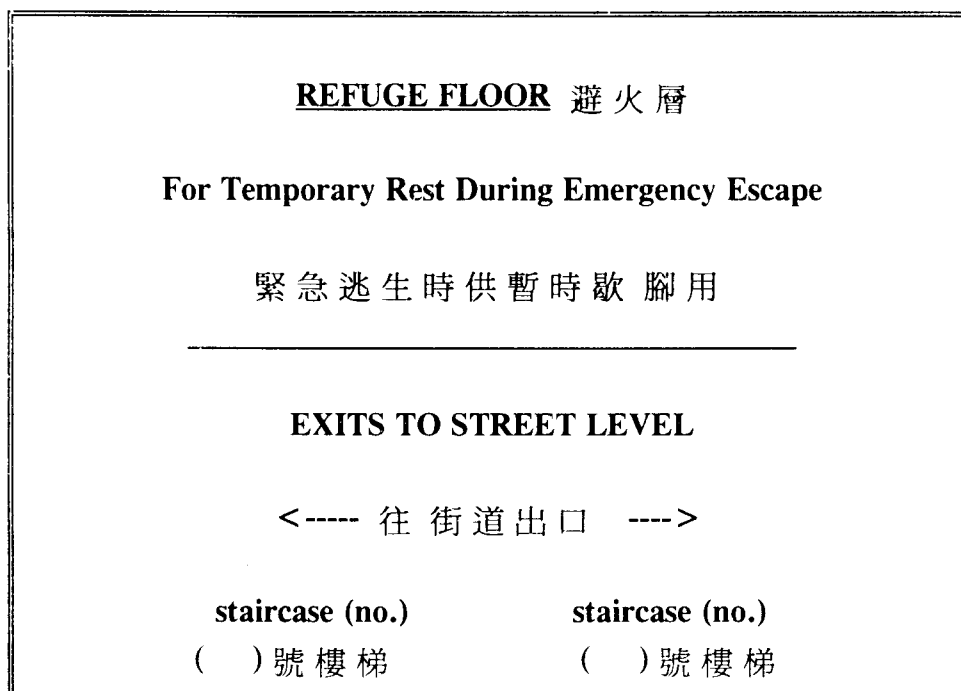

- (c) sufficient directional signs in the following form should be displayed at appropriate positions at the refuge floor at a height of 1500mm above the floor level, to indicate the direction of travel in order to enter the respective staircase number;

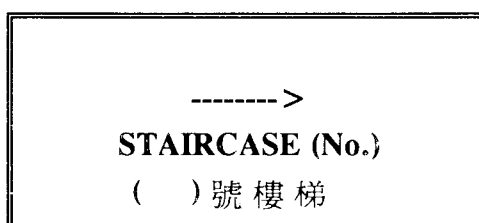

- (d) all signs and notices provided under (a), (b) and (c) should -
- (i) be in English and Chinese;
 - (ii) be illuminated by a light on two systems as the lighting referred to in paragraph 8.4;
 - (iii) have words and characters in block letters not less than 50mm high in white colour on a background in green or the words and characters in green on a background in white or black; and
 - (iv) not be easily defaced or damaged;

- (e) appropriate notices in English and Chinese in letters and characters not less than 25mm high should be provided in a conspicuous part at the main entrance of the building to indicate where the refuge floors are situated.

21.5 This paragraph does not apply to a domestic building or a composite building not exceeding 40 storeys in height above the lowest ground storey. In a domestic building or a composite building exceeding 25 storeys but not exceeding 40 storeys in height above the lowest ground storey, the main roof of the building should be a refuge floor and should comply with the requirements in paragraphs 21.3 and 21.4.

PART III : PROVISIONS OF MEANS OF ESCAPE IN PLACES OF PUBLIC ENTERTAINMENT

In addition to the general requirements in Part II, all places of public entertainment should comply with the requirements in this part.

22. Site

- 22.1 The site of a place of public entertainment should abut upon and have frontages to 2 or more thoroughfares.
- 22.2 The frontages of a building having a place of public entertainment should, subject to paragraph 22.7, form at least one-half of the total boundaries of the site on which the building is situated, excluding recesses and projections which do not prejudicially affect exit routes, and should permit of the provision of exit routes in accordance with this Code from each tier or floor direct to 2 or more thoroughfares.
- 22.3 The thoroughfares referred to in paragraph 22.2 should be of such widths as will enable the persons who are to be accommodated in the place of public entertainment to disperse rapidly in the event of fire or panic and as will afford reasonable facilities for the approach of fire appliances.

- 22.4 In the case of a place of public entertainment which is capable of accommodating more than 500 but not more than 2,000 persons one of the thoroughfares referred to in paragraph 22.2 should be at least 12 m wide.
- 22.5 In the case of a place of public entertainment which is capable of accommodating more than 2,000 but not more than 3,000 persons one of the thoroughfares referred to in paragraph 22.2 should be at least 12 m wide and the other one should be at least 9 m wide if a carriageway or 6 m wide if a footway.
- 22.6 In the case of a place of public entertainment which is capable of accommodating more than 3,000 but not more than 5,000 persons one of the thoroughfares referred to in paragraph 22.2 should be at least 15 m wide and the other one should be at least 9 m wide.
- 22.7 In the case of a place of public entertainment which is capable of accommodating more than 5,000 persons such further frontage to the thoroughfares referred to in paragraph 22.2 should be provided as the Building Authority may require.
- 22.8 In the case of a place of public entertainment which is capable of accommodating not more than 500 persons, the Building Authority should determine the number and width of thoroughfares required to be provided as access to the place of entertainment.

23. Cinemas in Multi-storey Non-domestic or Composite Buildings

- 23.1 Cinemas accommodating not more than 2,000 people in the aggregate in any one building may be situated in any one storey or storeys of a non-domestic building or the non-domestic part of a composite building.
- 23.2 Such cinemas may have shared facilities including exit routes. The exit routes should have adequate widths and sizes based on the total capacity of the cinemas to be served. The exits from the cinemas should be relatively remote from each other and the majority of exit routes should discharge to streets of not less than 4.5m wide which is accessible to fire fighting vehicles to the satisfaction of the Director of Fire Services and, if necessary, may discharge through but should be separated from other occupancies.

23.3 Such cinemas may be situated at the first basement only, subject to compliance with the following requirements :

- (a) all exit routes from the auditorium to the staircases and from the staircases to the streets should be short and direct;
- (b) all staircases/exits from the cinemas should discharge independently onto a street;
- (c) all staircases serving other basement floors should be sealed off at the floor where the cinemas are situated;
- (d) at least one of the exit routes should be a fire-fighting and rescue stairway designed and constructed in accordance with the Code of Practice for Means of Access for Fire-fighting and Rescue; and
- (e) the widths of the staircases should be in accordance with Table 7.

Table 7

No. of persons in each PPE	No. of exit routes required	widths of exit routes required
Less than 300	2	1.5m each
301 - 500	2	2m each
501 - 750	3	2m each
Over 750	to be decided by Building Authority	

24. Exit, Notices, etc

24.1 All exit doors or openings from a place of public entertainment and from the stage and dressing rooms in such place should be clearly indicated by a notice bearing the word EXIT in block letters in English and Chinese of letters not less than 175 mm high in white colour with a background in green or letters in green with a background in white or black.

- 24.2 Such notices should be at a height of at least 2 m above the floor and, where possible, should be placed over such doors or openings.
- 24.3 Doors and openings, other than exits, in sight of the audience, which lead to portions of the place of public entertainment accessible to the public, should have notices placed over them indicating the use of such portions and such doors and openings should not resemble exits.
- 24.4 Notices, signs and handpointers indicating the way out should be provided.
- 24.5 Notices bearing the words NO EXIT should not be provided.
- 24.6 Each notice indicating an exit should be illuminated by a light on two systems as the lighting referred to in paragraph 33.
- 24.7 The lighting of exit notices should not in any circumstances be extinguished or dimmed while the public are on the place of public entertainment.

25. Entrances and Exit Routes

- 25.1 Two separate exit routes should be provided from every tier or floor which is capable of accommodating not more than 500 persons, and one additional exit route should be provided for every 250 or part of 250 persons above 500.
- 25.2 Two of the exit routes from each tier or floor should open into different thoroughfares or ways.
- 25.3 If the tier or floor is capable of accommodating not more than 300 persons the width of each exit route should be not less than 1.2 m measured between the walls at any point or between the leaves of the doors when open, and if the tier or floor is capable of accommodating more than 300 persons the width of each of the exits should be not less than 1.5 m measured in like manner.
- 25.4 In the case of any places of public entertainment or portions thereof which are 12 m or more above pavement level the total width of exit routes should be 25 per cent in excess of the width required by paragraph 25.3.

- 25.5 If any tier or floor is divided into 2 or more parts exit routes as required by this paragraph should be provided from each of such parts.
- 25.6 In calculating the number of persons who can be accommodated in any tier or floor or part of a tier or floor, the accommodation of all standing and waiting spaces in such tier or floor or part of a tier or floor should be included and for the purpose of this paragraph, any tea room, lounge, restaurant or foyer should be regarded as a waiting space.
- 25.7 Exit routes should be arranged so as to afford a ready means of egress from all parts of each tier or floor and should lead directly into thoroughfares or ways.
- 25.8 In theatres and music halls and other places of public entertainment where the principal fire risk is on the stage, the exit routes from each part of each tier or floor should be placed in a position remote from the stage.
- 25.9 All entrances and exit doors, other than pass doors in connexion with spaces in which persons await admission, should be arranged so as to be available for exit during the whole of the time that the public are on the place of public entertainment.

26. Staircases

- 26.1 Staircases intended for the use of the public from any tier or floor or part of a tier or floor capable of accommodating not more than 300 persons should be in no part less than 1.2 m wide and such staircases from any tier or floor or part of a tier or floor accommodating more than 300 persons should be in no part less than 1.5 m wide.

- 26.2 Staircases referred to in paragraph 26.1 should -
- (a) not have winders;
 - (b) be in flights of not more than 16 or less than 3 steps each;
 - (c) not have more than 2 successive flights without a turn; and
 - (d) if there are more than 12 steps in a flight, should not have more than one flight without a turn.
- 26.3 Where a flight of steps in a place of public entertainment returns the newel wall should be chased so as to allow the handrail to turn without projecting over the landing.
- 26.4 Any recess in the walls of a staircase should be defended by guardrails.

27. Barriers

- 27.1 Any barriers which may be provided for checking or controlling admission should be arranged so that the portions immediately in the line of exit open automatically upon pressure being applied in the direction of exit and so as not to reduce the width of the exit route. All fixed directional barriers to define the exit route should have adequate strength complying with the requirements in section 17(3) of the Building (Construction) Regulations.
- 27.2 Rope barriers should be fitted with automatic catches or slip connexions and should be arranged so as not to trail on the floor when parted and the fittings should not project into the gangway or exit route.

28. Chains and Padlocks

Chains or padlocks should not be used to secure exit doors. When any other locking mechanism is used, the doors should be capable of being opened from inside without using a key.

29. Gangways and Seatways

- 29.1 Gangways not less than 1.05 m wide should be provided. Such gangways should -
- (a) lead direct to the exit doors; and
 - (b) intersect the rows of seating in such a manner that no seat should be more than 3 m from a gangway measured in the line of seating.
- 29.2 Where steps are provided in intersecting gangways, suitable hand-grips should be provided at the ends of the seats.
- 29.3 There should be no projection into a gangway which diminish the clear width of the gangway.
- 29.4 There should be an unobstructed way or space at least 300mm in depth, measured between perpendiculars, between the back of each seat and the front of the seat immediately behind.

30. Non-slippery Surfaces

All gangways and exit routes and the treads of steps and staircases should have non-slippery surfaces.

31. Edges of Steps

The edges of the tread of steps and staircases should be conspicuous.

32. Exit from Stages

- 32.1 Where a permanent stage is provided in a place of public entertainment an exit should be provided from each side of the stage, and one of such exits should lead direct to a street.
- 32.2 An exit leading direct to a street should be provided from the stage basement.

33. Lighting

All portions of a place of public entertainment to which the public have access should be provided with artificial lighting providing a horizontal illuminance at floor level of not less than 30 lux and backed up by an emergency lighting system providing a horizontal illuminance at floor level of not less than 2 lux. The design of the emergency lighting system should comply with the Code of Practice for Minimum Fire Service Installations and Equipment.

34. Temporary Buildings

The following requirements should apply to a temporary building which is intended to be used or which is licensed for a public entertainment :

- 34.1 There should be an unobstructed way or space of at least 300mm measured between perpendiculars between the back of one seat and the front of the seat immediately behind.
- 34.2 The seating should be fixed firmly to the ground, floor or decking and if separate chairs are used they should be securely battened together in lengths of not less than 4.
- 34.3 Gangways not less than 1.2m in width intersecting the rows of seating should be provided in such a manner that no seat should be more than 3m from a gangway measured in the line of seating, and there should be a gangway abutting each side of the building from which the exit ways should open.
- 34.4 Gangways not less than 1.2m in width at right angles to the longitudinal gangways required by paragraph 34.3 should also be provided in such a manner that the seating is divided into blocks not more than 9m in depth measured between perpendiculars between the front of the seats forming the front row and the back of the seats forming the back row of a block of seating.

- 34.5 Exit ways not less than 2.4 m in width should be provided in each side of the structure in such manner that there is one exit way at each end of a prolongation of the centre line of each of the gangways required by paragraph 34.4 and one such exit way is required at each end of a prolongation of a line 1.2 m in front of the first or front row of seating.
- 34.6 Such further exit ways as are considered necessary by the Building Authority should be provided from the area of the stage or the space provided for the performance.
- 34.7 Any door erected at the exit ways should open in the direction of exit and any fastening used for maintaining the doors closed should readily give way upon light pressure being applied by one person from inside.

I. COMMENTARIES

This edition of this Code of Practice is a revision of the 1986 edition. The reasons for and the rationale behind the major revisions are described in these commentaries to facilitate the users to readily understand the spirit of the provisions, thus assisting the interpretation thereof.

II. Deletion

1. The following paragraphs in the 1986 edition are deleted as the requirements specified therein, which concern fire resisting construction, are covered by the Code of Practice for Fire Resisting Construction :

11. Exits from flats and tenements
14. Enclosure of staircases
23. Windows in external walls
24. Doors in light wells
- 25(6). Basements - smoke vents
26. Garages and car ports attached to buildings

Requirements concerning fire resisting construction in the various other paragraphs are also deleted for the same reason.

2. Paragraph 27 - Domestic occupancies in certain buildings - in the 1986 edition is deleted as it is considered superfluous.

3. The following definitions in the 1986 edition are deleted as these terms are not used in this edition :

FRP, Institutional Building, Lobby, Protected Corridor, Protected Staircase, Residential Building, Staircase (External), Staircase (Internal), Staircase (Partly External).

III. Major Revisions/New Requirements

1. Use of the Code

This is a new paragraph which states the use of the Code.

2. Objectives

This is a new paragraph which specifies the objectives of the Code.

3. Alternative Approach to Fire Safety

This is a new paragraph which states the fire safety engineering is accepted as an alternative approach to fire safety.

4. Interpretations

Interpretations (definitions) are added or modified :

‘Balcony approach’ - Only a balcony serving two or more occupancies is acceptable in order to avoid using part of a private premises, e.g. an open-sided utility, as balcony approach and to avoid abuse use of the area.

‘Maisonette’ - The maximum number of storeys is restricted to 3 corresponding to the application of this Code.

‘Travel Distance’ - This is measured outside a room; the distance within a room is now called "direct distance". The travel distance restriction applies to podium level where there are accommodations at that level and ground storey.

5. Application

Houses for single family nowadays often have 4 storeys and split-level design. To allow flexibility in house design while safety is not forsaken, the necessity for stringent means of escape requirements is relaxed for houses up to 3 main domestic storeys and 13 m height. Two split levels may be regarded as one main storey and the carport floor, which is usually at G/F, needs not be counted as a main storey.

6. Special Hazard Occupancy

Escape from normal hazard shall not pass through special hazard as escape should be towards safety and not the reverse.

7. Assessment of Accommodation

Table 1 should be taken as minimum standard irrespective of whether the detailed layout or seating plan is known or not. Uses not covered by Table 1 should be individually assessed by the Building Authority.

8. General Requirements of Exit Routes

- 8.1 Exit routes should lead to a street, either directly or through an open area at ground level. Exit routes discharging to a podium first and then discharge from there to a street are not acceptable unless the criteria stipulated in the Code have been complied with.
- 8.2 If an exit route discharges to a private lane, it must be ensured that a right of way exists otherwise the owner of the lane is entitled to prohibit passage through the lane.
- 8.3 As an exit route may be used at any time (a fire may break out at night), artificial lighting must be provided. 30 lux is the minimum lighting level for circulation areas and 2 lux is the level for emergency lighting specified by the Director of Fire Services. Emergency lighting should be provided to any part of an exit route whether it is a partially protected zone (corridors) or a fully protected zone (staircases).

- 8.4 At the final point of discharge, exit routes should not be close together unless there is adequate separation to prevent fire and smoke spread between one another. Also at this point, a drop in level is required by Building (Construction) Regulation 35. To avoid the danger of falling of people when escaping, any door or gate across the exit route at this point should be set back from the drop in level so that people will have sufficient time to realise the drop.

9. Buildings with a Single Staircase

- 9.1 Buildings are permitted to have a single staircase as a "concession" to the normal provisions in consideration of the limitations to such buildings as to the size, usage and height as stipulated in this Code.
- 9.2 As the roof of a single staircase building in which the level of the highest floor is more than 13m above ground level is used as a secondary exit - an area for refuge to wait for rescue, it should be designed and constructed to have sufficient flat space to accommodate all the occupants of the building except those of the G/F and be accessible for rescue purpose.
- 9.3 In normal situation, where vehicular access is available, the roof should be so arranged as to be readily accessible to rescue appliance. However, if vehicular access is not available, the Director of Fire Service may consider to impose other conditions such as enhanced fire service installations to ensure safety of the occupants.

10. Exits from Rooms

Basically all rooms should be provided with proper exit doors but, in order not to restrict the freedom of design of small rooms such as bedrooms and bathrooms while safety is not forsaken, rooms accommodating more than 3 persons are required to comply with the exit door requirements.

11. Exit from Storeys

11.1 As a maisonette is similar to a building having not more than three main domestic storeys, the requirements of this Code need not apply within a maisonette. A proper exit, however, should be provided at least to one of the floors of the maisonette for escaping to the main exit route of the building in which the maisonette is situated.

11.2 Although staircases are designed to be fire and smoke proof, there will still be rare occasions when a staircase is smoke logged or even on fire and, more often, obstructed. To allow for such contingencies, a building has to be so designed that the staircases are linked by common passages or areas in the building, i.e. not through private premises which may be locked up at times.

12 Exits at Ground Storey

The exit routes at ground level should have adequate separation from the remainder of the building. Other uses in ground floor will normally not be allowed to open-off the passage-way of an exit staircase. If exit routes discharge onto the passage-way at ground floor, they should have adequate width to prevent "bottleneck" effect.

13. Access to Staircase(s) within a Building

- 13.1 As a protected lobby to separate a staircase from the general accommodation of the building is for the purpose of impeding the passage of smoke, the provision of such a lobby should not depend on the height of the building but rather whether the passage leading to the staircase (balcony approach) or the staircase itself (open-sided staircase) is adequately ventilated. To ensure that any smoke entering such a lobby may affect one staircase only, separate lobby should be provided to each staircase.
- 13.2 The use of common corridor/lobby, utility area, maids quarter, etc. as a protected lobby is not acceptable.

14. Direct Distance and Travel Distance

- 14.1 A room is considered as an unprotected zone. The distance of travel within a room should therefore be limited. A corridor or balcony approach is considered as a partially protected zone [i.e. comparatively safer than within a room]. Thus, the distance of travel along a corridor or balcony approach may be longer than that within a room. In order to distinguish the different criteria, the terms "direct distance" and "travel distance" are used to represent the distance of travel respectively within an unprotected zone and a partially protected zone.
- 14.2 As the time required for the occupant(s) travelling within the unprotected and the partially protected zone to the fully protected zone [i.e. protected staircase(s)] should not be too long, the total distance of travel within these unprotected and partially protected zones is also limited.
- 14.3 It is considered that the approach to the protected zone through a balcony or a ventilated protected corridor should have a higher level of safety than other methods of approach because the smoke, if any, can, to some extent, be dispersed by ventilation. Thus, the travel distance and the sum of direct distance and travel distance for such method of approach is allowed to be longer.
- 14.4 When a secondary exit door is required to be provided to room it should not be too close to the other exit door, otherwise it will lose its effect as an alternative exit. Thus, a "30° separation" is required.

14.5 A room (inner room) from which the only escape route is through another room (access room) is at risk if a fire starts in the access room. Special requirements are therefore imposed to ensure a safe escape route from an inner room.

15. Discharge Value and Width of Staircase

15.1 The escape staircases should have a "discharge value" to allow all floors to be evacuated simultaneously i.e. total evacuation.

15.2 The discharge value tables are formulated on the following basis :

(a) the escape strategy is based on the total evacuation of the building;

(b) evacuation (from a storey to a protected area) within a notional period of 2.5 minutes for non-sprinklered buildings and 5 minutes for sprinklered buildings;

(c) the flow rate of people in descending the staircase is taken to be 80 persons/metre width/minute; and

(d) the number of people temporarily housed in the staircases during evacuation is taken to be 3.50 - 3.90 persons/square metre.

15.3 As experiments have shown that the ascending flow rate of people is approximately 80% of that for descending, a reduction factor of 0.8 is applied for calculating the discharge value for staircases where the direction of exit is upward.

15.4 The staircase geometry of traditional 2-flight staircases and scissors staircases are different. As the number of people that can be temporarily housed in a scissors staircase is approximately 70% of that in a 2-flight staircase, a reduction factor of 0.7 is applied where the exit staircases is a scissors staircases without any intermediate landing between 2 consecutive floors.

15.5 In adopting the above mentioned figures reference has been made to the UK and American standards and research results.

15.6 Where two or more staircases are provided, it is necessary to discount one staircase for calculating the discharge value on the assumption that one of the staircases might not be available due to smoke. No discount is required in this Code because all staircases in a building, other than some single staircase building, are required to be approached through a protected lobby or are ventilated and staircases are also linked by common passages in the building.

15.7 People in a place of large occupancy would move rapidly to exits and reach them at about the same time in case of stadia, sports arenas, passenger terminals, etc., which would require them to wait before going through the exit. If queuing time was too long, huge "crowd pressure" would be created. The critical factor influencing the queuing time would in general be the aggregate width of the exits and the staircases. Thus, the total width of the staircases serving such place of large occupancy should be increased to 1.2 times that of the exit routes to reduce the queuing time to an acceptable level. The method of calculation can be expressed by the following equations :-

i) Where all exits lead to staircases :

$$W = 1.2 \times T$$

where W = total width of staircases serving the place of large occupancy.

T = total width of exits assessed by Table 2 from the occupant load of the place of large occupancy

ii) Where part of the exits lead to a place of ultimate safety and part of them lead to staircases :

$$W = 1.2 \times T^1$$

where $T^1 = T -$ (total width of exits leading directly to the place of ultimate safety)

15.8 Other buildings having a large capacity, fire engineering approach should be adopted.

16. Doors in Relation to Exits

- 16.1 Doors across exit routes should not normally be locked. However, for security purposes a mechanical or electrical locking device is acceptable provided that the doors are capable of being readily opened from the inside without the use of a key. For a door to a staircase or the lobby of the staircase, it is important that it should also be capable of being opened, in case of fire, from within the staircase or the lobby to allow people to re-enter the floor in order to go to another staircase. This may be achieved by an electro magnetic lock or other kinds of locking device which is capable of being released automatically in case of fire. Notwithstanding the aforesaid actuation means, the locking device on exit doors should be capable of being released automatically upon power failure. Any other means of securing the doors are not acceptable.
- 16.2 Exit routes in a building are usually circulation areas in normal times. Doors across such routes are often held open to facilitate circulation. To avoid the doors being held open by arbitrary methods, the use of specially designed hold-open devices, which is capable of being released automatically in case of fire, is encouraged. This, however, does not apply to a door to a staircase or the lobby of the staircase which, being the final part of the escape route, should be kept safe at all times.
- 16.3 Double leaf doors with flush meeting stiles are preferred over those with rebates the smoke seal effect of which will be lost if not closed fit. A checking device should therefore be provided for such doors to ensure the doors are closed in the correct order.

17. Construction of Staircases

The exit staircases should be constructed to provide safe evacuation and the staircase geometry should be so arranged to provide a reasonable rate of flow of the evacuees.

18. Ramps

Although means of escape for the disabled is not covered in this Code, there is no technical difficulty to make the gradient of exit ramps to be 1:12 to coincide with that for access ramp for the disabled.

19. Lift Lobbies

Buildings are often so designed that lifts are not adjacent to staircases. When the entrance from the lift lobby to the floor is locked, people coming out from the lift will be trapped in the lobby. To avoid such dangerous situation in case of fire, a lift lobby should be so located that either it has direct access to a staircase or it is linked to a staircase through a common passage or area which should not be locked up at any time. The provision of a direct intercom link will be accepted as an alternative approach if the building is expected to have good management.

20. Basements

20.1 People always tend to escape down a staircase rather than up. This is dangerous in the case of a basement when the escape should be in an upward direction. Directional signs should, therefore, be required to guide people to go up rather than down. In spite of signs being provided, people may still get confused and there may thus be difficulty in locating the correct level of the exit to street. To make the exit to street clear, staircases serving the basements should not be continued to serve the upper floors also.

20.2 As far as escape in case of fire is concerned genuine basements are the most hazardous and difficult situation. An independent exit to street is, therefore, required to each basement to enhance the means of escape. A genuine basement is one which is completely below ground, i.e. below the lowest ground storey and all the exit routes are in an upward direction.

21. Refuge Floors

- 21.1 A refuge is an essential part of the exit routes in tall buildings. It acts as a safe place for a short rest before people continue to escape downwards because it is difficult for most people to walk down a tall building in one go. It acts as a safe passage for people using one staircase, when encountering smoke, fire or obstruction in that staircase, to go to another staircase. It also acts as a place of assembly for people to wait for rescue in case all the staircases cannot be used due to smoke, fire or obstruction. To perform these functions well, a refuge floor should be a safe and comfortable place to stay. It should have sufficient area to accommodate most of the occupants of about 20 floors (10 above and 10 below). It should have adequate height, lighting, ventilation as well as signs. It is important to ensure that the area is free from obstructions and to maintain the signage and lighting. Good management therefore plays an essential role in maintaining the function of a refuge floor.
- 21.2 As the mandatory requirement of refuge floors in all tall buildings is firstly introduced in this edition of the Code, domestic buildings and composite buildings, which are considered to have lower risk in that the building will have relatively smaller compartment and the occupants will be familiar with the layout of the building, are initially relaxed up to 40 storeys before such a building requires a refuge floor. However for such a building which is more than 25 storeys but less than 40 storeys in height, use should still be made of the main roof for refuge by designing it as a refuge floor. For other types of building, 25-storey is considered as high-rise and a refuge floor should be required. Application of refuge floor requirement for domestic buildings and composite buildings is an incremental approach. The requirement will be reviewed in the light of experience and if it could be proved to be feasible, application to domestic buildings below 40 storeys will be imposed.
- 21.3 Signs indicating where the refuge floor(s) in the building will be situated shall be provided in the conspicuous part, such as main entrance, of the building in order to help the occupants/firemen to locate the refuge floor(s).
- 21.4 As water which may accumulate on a refuge floor will affect the safety use of the area for refuge, a refuge floor should be suitably waterproof and drained.

IV. Places of Public Entertainment

The means of escape requirements for places of public entertainment are transferred from the Places of Public Entertainment Regulations and Practice Note to Authorized Persons and Registered Structural Engineers 54 in pursuance of a proposal to delete all matters concerning the design, planning and construction of buildings from the said Regulations.

V. Means of Escape for the Disabled

This Code does not cover provisions of means of escape for the disabled. However, designers are recommended to take this into account in the design of the building. In this connection, reference may be made to BS5588 Part 8:1988. As a minimum provision, a communication panel may be installed adjacent to the fireman's lift as a "call point" for help for the disabled in case of fire.

Diagram 1 : ACCESS TO STAIRCASES WITHIN A BUILDING

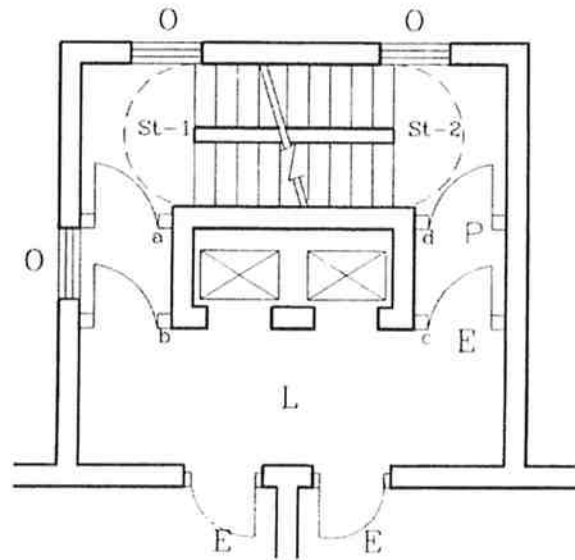

P	Protected lobby	see paragraph 4 & 13.5 (b)
O	Opening (if any)	comply with the requirements in FRC Code
E	Exit doors	see paragraph 16
L	Lift lobby	see paragraph 19
a-b-c-d	Separation between the door of 2 staircases	minimum 6m measured along the wall [see para. 13.3(b)]

Diagram 2 : INTERNAL CORRIDOR ACCESS

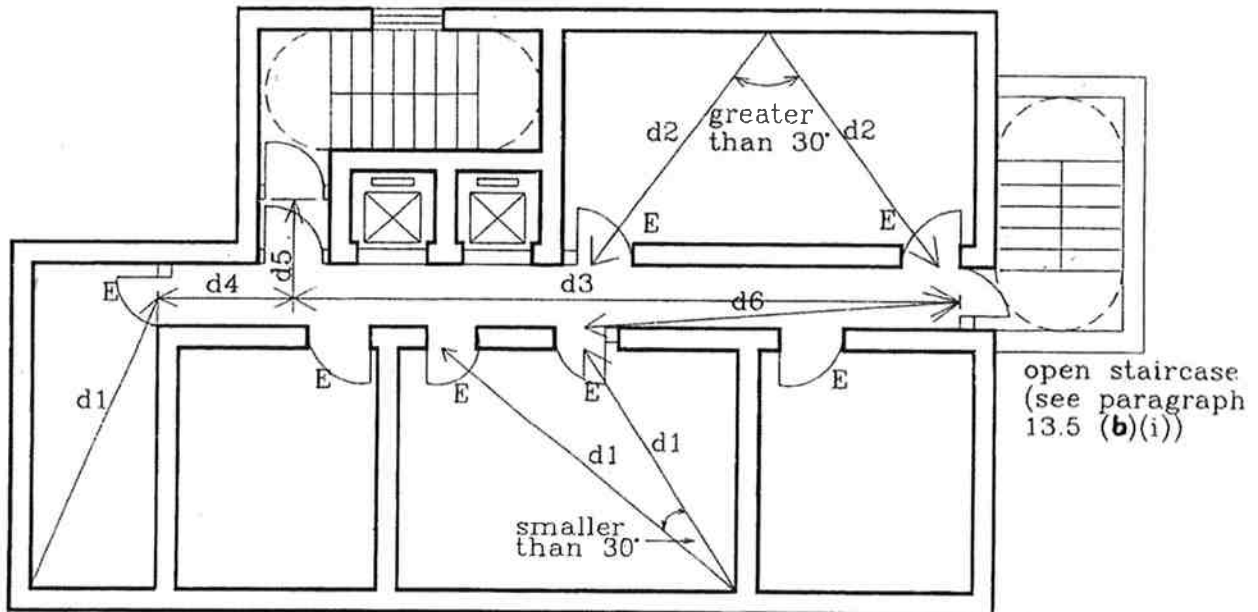

E Exit door

d1 Direct distance max. 15m [see para. 14.1]

d2 Direct distance max. 18m [see para. 14.1 & 14.6]

d3+d5 Staircases separation max. 48m [see para. 14.3(c)]

d1+d4 Deadend max. 18m [see para. 14.3(b)]

d6 Travel distance

d1+d6 sum of direct distance
d1+d4+d5 and travel distance

} Limitations stated in
} Table 4
}

Diagram 3 : EXTERNAL BALCONY APPROACH

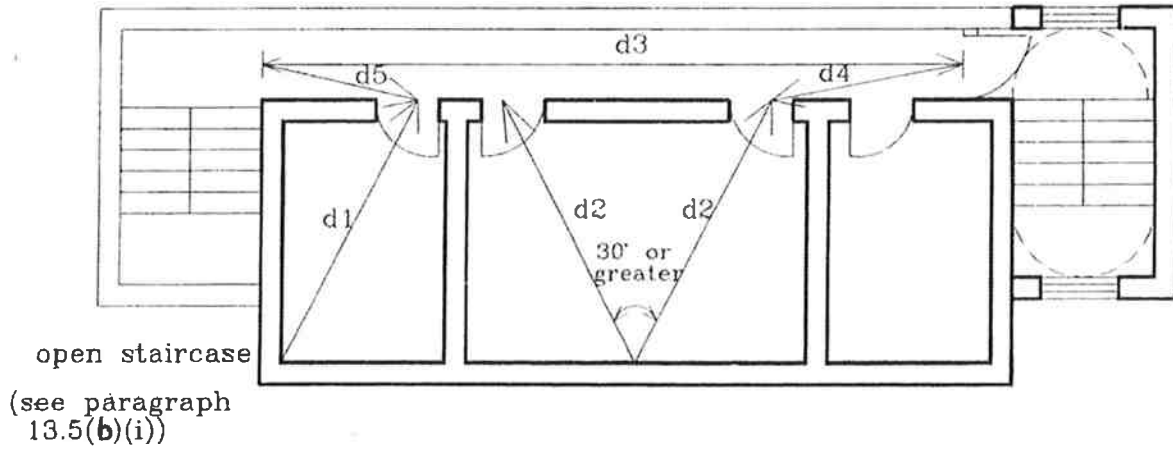

d1	Direct distance	max. 15m [see para. 14.1]
d2	Direct distance	max. 18m [see para. 14.1 & 14.6]
d3	Staircases separation	max. 48m [see para. 14.3(c)]
d4,d5	Travel distance)
d1+d5, d2+d4	Sum of direct distance and travel distance) Limitations stated in Table 4

Diagram 4 : LAYOUT WITHOUT INTERNAL CORRIDOR

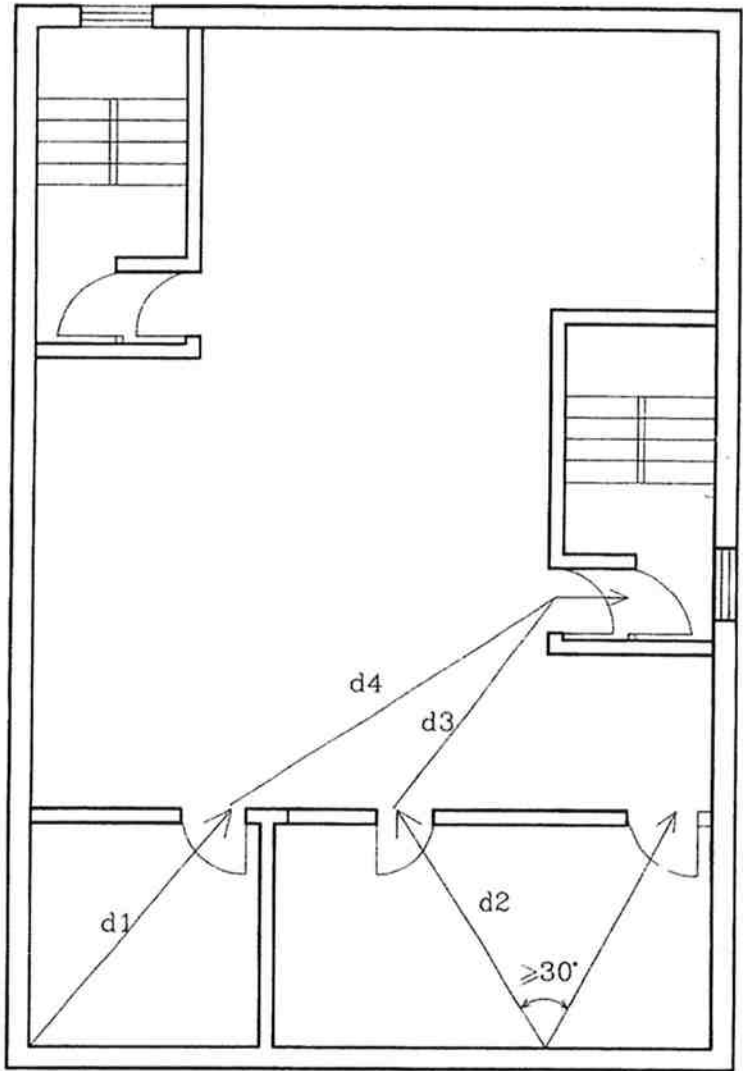

d1	Direct distance	max. 15m [see para. 14.1]
d2	Direct distance	max. 18m [see para. 14.1 & 14.6]
d3,d4	Travel distance)
d1+d4, d2+d3	Sum of direct distance and travel distance) Limitations stated in Table 4

Diagram 5 : OPEN PLAN LAYOUT

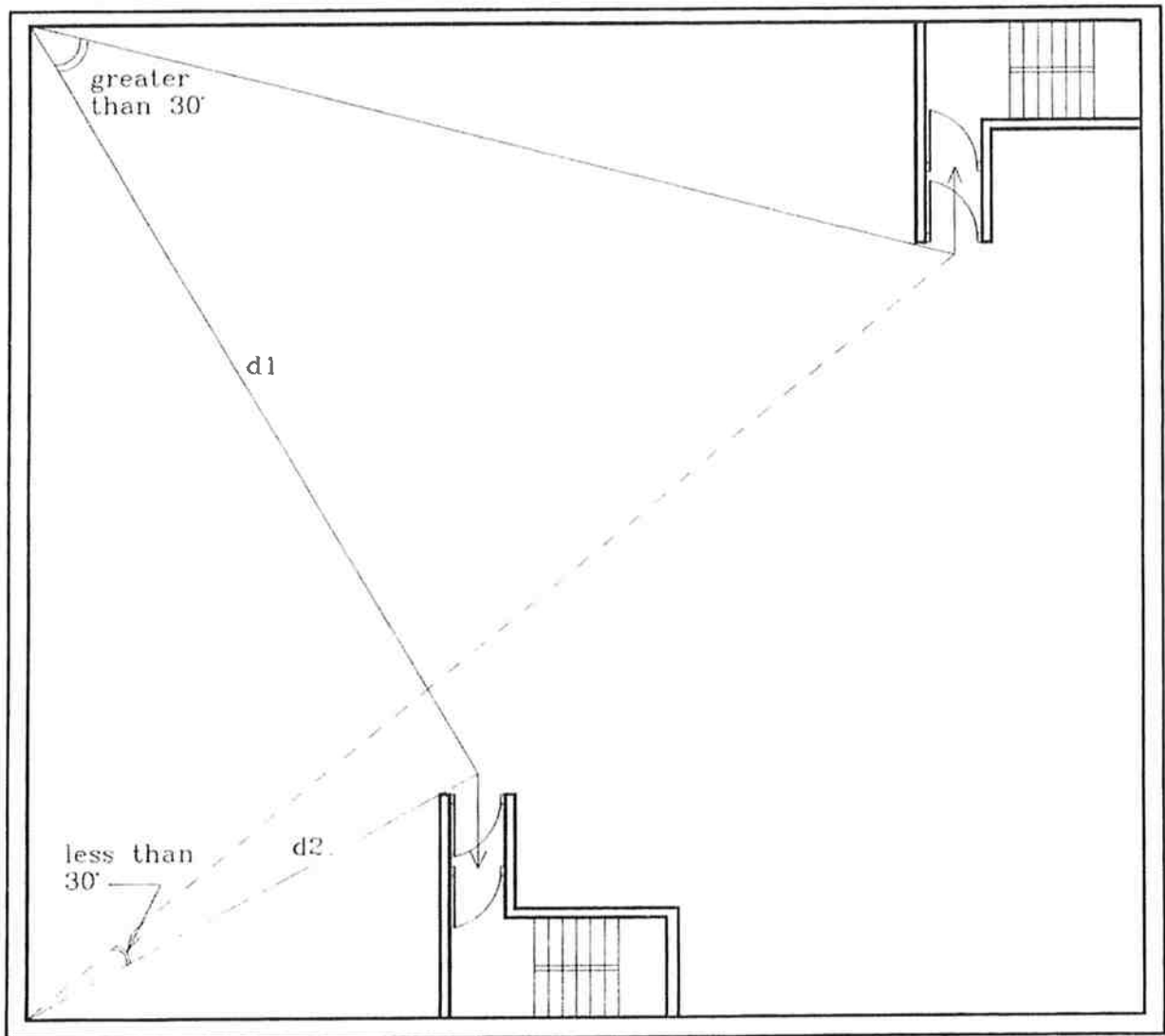

- | | | |
|----|---------------------------|---------------------------|
| d1 | Direct distance | max. 30m [see para. 14.4] |
| d2 | Direct distance (deadend) | max. 18m [see para. 14.4] |

Diagram 6 : TYPICAL LAYOUT OF REFUGE FLOOR

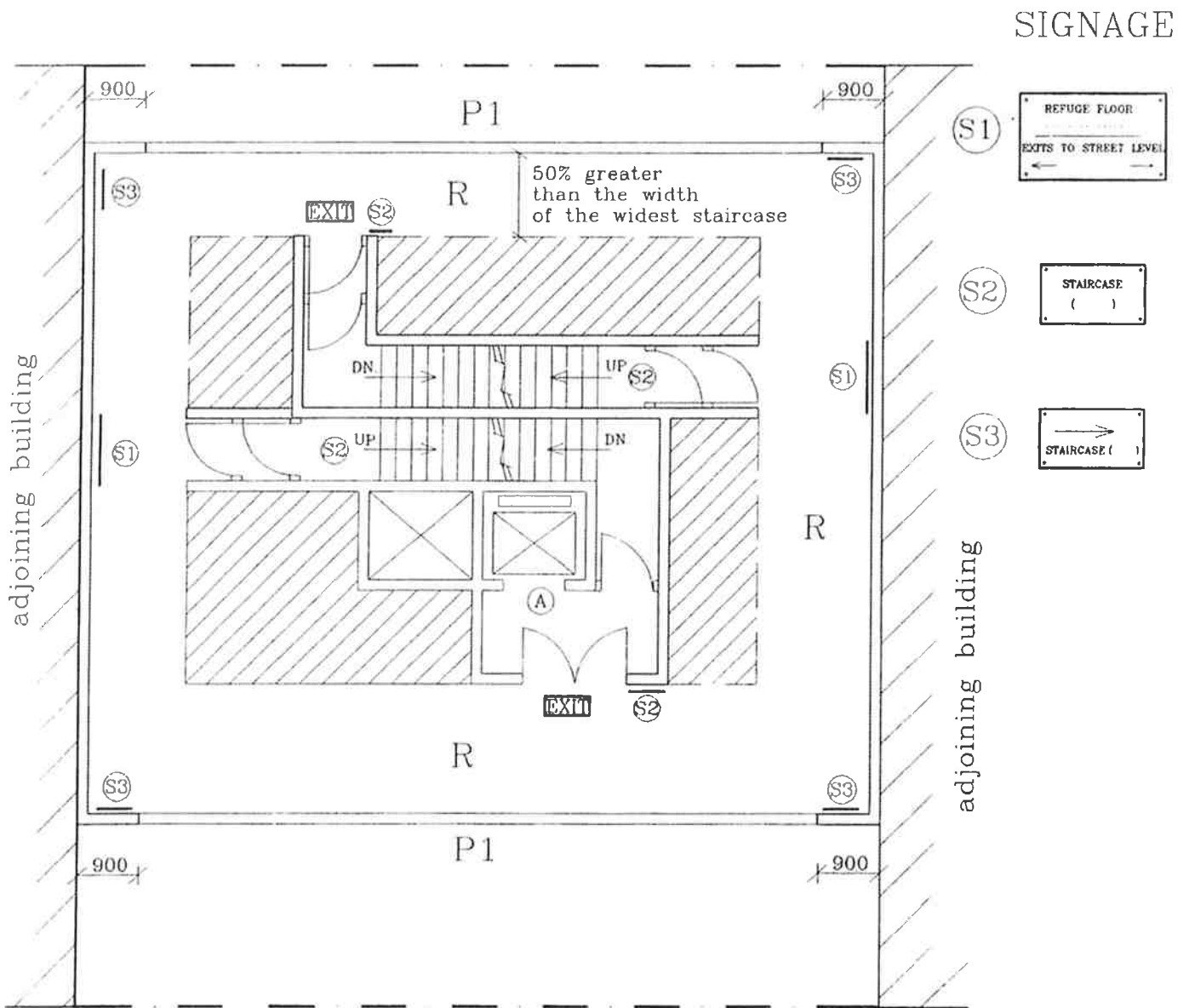

Permitted fire service water tank and associated fire service installation plant room; or other mechanical plant room (not accessible from refuge floor)

[para. 21.2(a)]

R

Refuge floor (min. 50% of the floor area)

[para. 21.2(b)]

P1

Open-sided above parapet height for cross-ventilation

[para. 21.2(e)]

(A)

Firemen's lift serves refuge floor but doors locked [para. 21.2(i)] during normal operation

Diagram 7 : Exit Staircase Leading to an Open Area at Upper Floor
 (The Exit route across the open area should be designed and constructed as if it is part of the exit staircase)

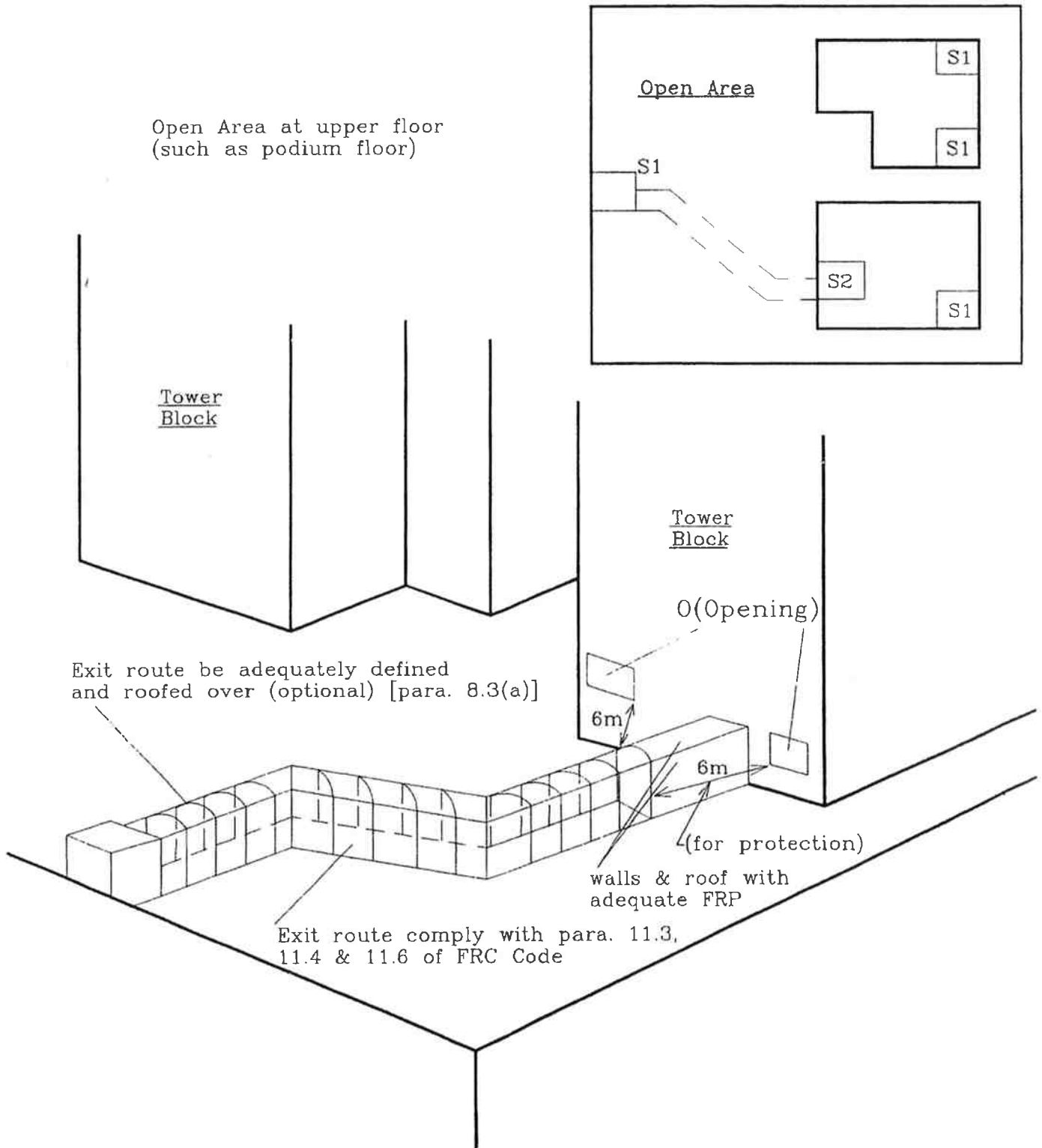

Remarks :

- S1 - staircase leading to place of ultimate safety
- S2 - staircase discharging to open area at upper floor level (e.g. podium floor)
- O - opening not protected by fixed light [para. 11.7(iii) of FRC Code]